

Tooling Flanges

Vlier's tooling flanges are compatible with a wide variety of spring-loaded devices and tooling fixture components, and are ideal for fixtures that require a horizontal application of a 1/4-20 and 1/2-13 threaded spring-loaded device.

Typical Uses



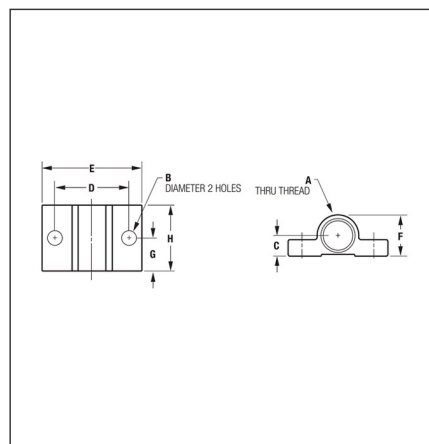
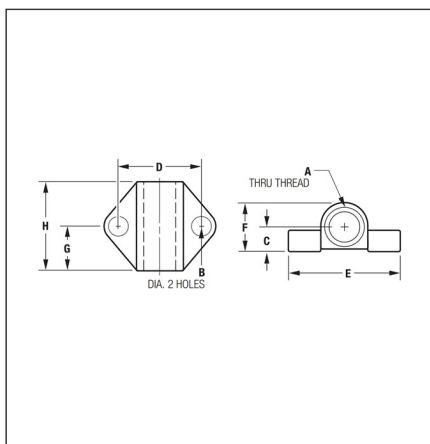

Workholding and fixtures applications.

Special Features

- Eliminates need for custom tooling blocks
- Works with a wide range of devices and products



Tooling Flanges

Part No.	A	B	C	D	E	F	G	H	ROHS	CAD
TF25 	1/4-20	0.136	0.22	0.66	0.88	0.41	0.34	0.69	<input checked="" type="checkbox"/>	TF25 
TF50 	1/2-13	0.203	0.31	1.13	1.50	0.63	0.50	1.00	<input checked="" type="checkbox"/>	TF50 

Product not available in metric.

Proud to be ISO:50001 and ISO:9001 Certified

Cage Code: 01226



Copyright © 2024 Vlier Inc. | All Rights Reserved | A Division of  HUTCHINSON®