

# Leveling Devices

## Original Series Stud Style Stainless Steel

Vlier original series stud style leveling devices in stainless steel offer maximum protection against rust and corrosion. They provide an integrally machined stud as part of the ball. The bases swivel 15° off the centerline to adjust to uneven surfaces and level equipment including machine tools, electronic racks, benches, data storage, power generation, machine centers and others.

### Typical Uses







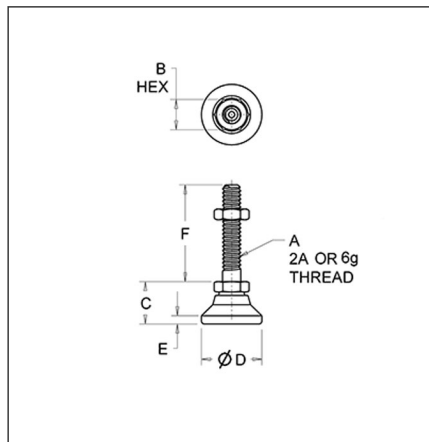







- Data storage equipment
- Large medical equipment
- Material handling equipment
- Industrial workstations
- Industrial machines

### Special Features











- Hardened ball
- Stud with integrally machined hex
- Large diameter base support
- 15° swivel off centerline
- Stainless steel option resists rust and corrosion



## Original Series Stud Style - Stainless Steel

Part No.	Max Load (Lbs.)	A	B	C	D	E	F	ROHS	Part No.
SSP298S 	700	10-32	3/8	17/32	3/4	7/64	1	<input checked="" type="checkbox"/>	SSP298S 
SSP300S 	1,100	1/4-20	1/2	45/64	1	5/32	1-1/4	<input checked="" type="checkbox"/>	SSP300S 
SSP304S 	3,750	3/8-16	5/8	7/8	1-1/4	3/16	2	<input checked="" type="checkbox"/>	SSP304S 
SSP306S 	5,000	1/2-13	3/4	1-1/8	1-7/8	1/4	2	<input checked="" type="checkbox"/>	SSP306S 
SSP308S 	6,000	5/8-11	7/8	1-1/4	2-1/2	5/16	2	<input checked="" type="checkbox"/>	SSP308S 
SSP310S 	7,200	3/4-10	1-1/16	1-1/2	3	1/2	2	<input checked="" type="checkbox"/>	SSP310S 
SSP312S 	22,000	1-8	1-3/8	1-7/8	4	13/32	4-1/4	<input checked="" type="checkbox"/>	SSP312S 

## Original Series Stud Style – Stainless Steel Base - Stainless Steel Stud

Part No.	Max Load (kg.)	A	B	C	D	E	F	ROHS	Part No.
SSPM10S 	1,750	M10x1.5	17	22	32	5	51	<input checked="" type="checkbox"/>	SSPM10S 
SSPM12S 	2,273	M12x1.75	19	29	48	6	51	<input checked="" type="checkbox"/>	SSPM12S 
SSPM16S 	2,727	M16x2.0	24	32	64	8	51	<input checked="" type="checkbox"/>	SSPM16S 
SSPM20S 	3,273	M20x2.5	30	38	76	13	51	<input checked="" type="checkbox"/>	SSPM20S 
SSPM24S 	9,979	M24x3.0	35	48	102	10	108	<input checked="" type="checkbox"/>	SSPM24S 

Proud to be [ISO:50001](#) and ISO:9001 Certified

Cage Code: 01226



Copyright © 2024 Vliet Inc. | All Rights Reserved | A Division of  | HUTCHINSON®