

Posi-Hex™ Ball Plungers

Steel

The enhanced design of our Posi-Hex™ ball plungers allows for easy installation and removal using only a hex wrench. Designed to withstand maximum installation torque, Posi-Hex™ works great when using our thread locking element. These compact spring plungers offer quick change-outs that save downtime and money. Posi-Hex™ plungers withstand maximum torque and are recommended for use with nylon locking elements.

Typical Uses

- Indexing
- Locating
- Detents
- Positioning
- Electrical contacts
- Adjustable set screw

Special Features

- Will withstand maximum installation torque
- Quick installation & removal
- Controlled end forces

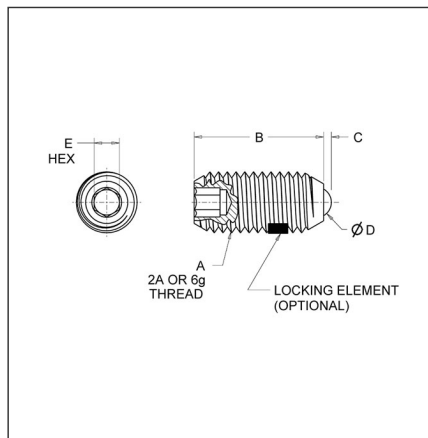





































































Posi-Hex™ Ball Plungers - Steel

Part No.		End Force, (Lbs.)		A	B	C	D	E	ROHS	CAD	CAD With Thread Lock
	With Thread Lock	Initial	Final								
PHB48A	PHB48AP	0.5	1.00	6-40	0.350	0.023	0.078	0.050	<input checked="" type="checkbox"/>	PHB48A	PHB48AP
PHB50	PHB50P	0.5	1.25	8-32	0.445	0.025	0.094	0.063	<input checked="" type="checkbox"/>	PHB50	PHB50P
PHB52	PHB52P	1.5	3.00	10-32	0.570	0.025	0.094	0.079	<input checked="" type="checkbox"/>	PHB52	PHB52P
PHB54	PHB54P	3.0	7.00	1/4-20	0.675	0.035	0.125	0.079	<input checked="" type="checkbox"/>	PHB54	PHB54P
PHB56	PHB56P	4.0	9.00	5/16-18	0.720	0.04	0.156	0.095	<input checked="" type="checkbox"/>	PHB56	PHB56P
PHB58	PHB58P	5.0	10.00	3/8-16	0.800	0.048	0.188	0.156	<input checked="" type="checkbox"/>	PHB58	PHB58P
PHB60	PHB60P	6.0	12.00	1/2-13	1.050	0.072	0.281	0.219	<input checked="" type="checkbox"/>	PHB60	PHB60P
PHB62	PHB62P	9.0	18.00	5/8-11	1.200	0.096	0.375	0.253	<input checked="" type="checkbox"/>	PHB62	PHB62P









Posi-Hex™ Ball Plungers - Steel w/Nylon Ball





























































Part No.		End Force, (Lbs.)		A	B	C	D	E	ROHS	CAD	CAD With Thread Lock
	With Thread Lock	Initial	Final								
DPHB48A	DPHB48P	0.5	1.00	6-40	0.35	0.023	0.078	0.05	<input checked="" type="checkbox"/>	DPHB48A	DPHB48P
DPHB50	DPHB50P	0.5	1.25	8-32	0.445	0.025	0.094	0.063	<input checked="" type="checkbox"/>	DPHB50	DPHB50P
DPHB52	DPHB52P	1.5	3.00	10-32	0.57	0.025	0.094	0.079	<input checked="" type="checkbox"/>	DPHB52	DPHB52P
DPHB54	DPHB54P	3.0	7.00	1/4-20	0.675	0.035	0.125	0.079	<input checked="" type="checkbox"/>	DPHB54	DPHB54P
DPHB56	DPHB56P	4.0	9.00	5/16-18	0.72	0.040	0.156	0.095	<input checked="" type="checkbox"/>	DPHB56	DPHB56P
DPHB58	DPHB58P	5.0	10.00	3/8-16	0.8	0.048	0.188	0.156	<input checked="" type="checkbox"/>	DPHB58	DPHB58P
DPHB60	DPHB60P	6.0	12.00	1/2-13	1.05	0.072	0.281	0.219	<input checked="" type="checkbox"/>	DPHB60	DPHB60P
DPHB62	DPHB62P	9.0	18.00	5/8-11	1.25	0.096	0.375	0.253	<input checked="" type="checkbox"/>	DPHB62	DPHB62P

Posi-Hex™ Ball Plungers - Steel

Part No.			End Force, N		A	B	C	ØD	HEX	ROHS	CAD	CAD With Thread Lock
	With Thread Lock	Initial	Final									
PHBM4	 PHBM4P		4.0	10.0	M4 x 0.7	11.2	0.8	2.5	2.0	<input checked="" type="checkbox"/>	PHBM4 	PHBM4P 
PHBM5	 PHBM5P		8.0	14.0	M5 x 0.8	14.4	0.9	3.0	2.5	<input checked="" type="checkbox"/>	PHBM5 	PHBM5P 
PHBHM5	 PHBHM5P		15.0	22.0	M5 x 0.8	14.4	0.9	3.0	2.5	<input checked="" type="checkbox"/>	PHBHM5 	PHBHM5P 
PHBM6	 PHBM6P		9.0	13.0	M6 X 1.0	17.0	1.0	3.5	2.5	<input checked="" type="checkbox"/>	PHBM6 	PHBM6P 
PHBHM6	 PHBHM6P		28.0	40.0	M6 X 1.0	17.0	1.0	3.5	2.5	<input checked="" type="checkbox"/>	PHBHM6 	PHBHM6P 
PHBM8	 PHBM8P		15.0	30.0	M8 x 1.25	18.2	1.5	5.0	2.5	<input checked="" type="checkbox"/>	PHBM8 	PHBM8P 
PHBLM8	 PHBLM8P		5.0	10.0	M8 x 1.25	18.2	1.5	5.0	2.5	<input checked="" type="checkbox"/>	PHBLM8 	PHBLM8P 
PHBHM8	 PHBHM8P		40.0	60.0	M8 x 1.25	18.2	1.5	5.0	2.5	<input checked="" type="checkbox"/>	PHBHM8 	PHBHM8P 
PHBM10	 PHBM10P		20.0	35.0	M10 x 1.5	22.9	2.0	6.0	4.0	<input checked="" type="checkbox"/>	PHBM10 	PHBM10P 
PHBLM10	 PHBLM10P		8.0	15.0	M10 x 1.5	22.9	2.0	6.0	4.0	<input checked="" type="checkbox"/>	PHBLM10 	PHBLM10P 
PHBHM10	 PHBHM10P		60.0	90.0	M10 x 1.5	22.9	2.0	6.0	4.0	<input checked="" type="checkbox"/>	PHBHM10 	PHBHM10P 
PHBM12	 PHBM12P		30.0	55.0	M12 x 1.75	26.6	2.5	8.0	6.0	<input checked="" type="checkbox"/>	PHBM12 	PHBM12P 
PHBLM12	 PHBLM12P		10.0	20.0	M12 x 1.75	26.6	2.5	8.0	6.0	<input checked="" type="checkbox"/>	PHBLM12 	PHBLM12P 
PHBHM12	 PHBHM12P		75.0	115.0	M12 x 1.75	26.6	2.5	8.0	6.0	<input checked="" type="checkbox"/>	PHBHM12 	PHBHM12P 
PHBM16	 PHBM16P		41.0	86.0	M16 x 2.0	31.7	3.5	10.0	8.0	<input checked="" type="checkbox"/>	PHBM16 	PHBM16P 
PHBLM16	 PHBLM16P		20.0	40.0	M16 x 2.0	31.7	3.5	10.0	8.0	<input checked="" type="checkbox"/>	PHBLM16 	PHBLM16P 
PHBHM16	 PHBHM16P		68.0	142.0	M16 x 2.0	31.7	3.5	10.0	8.0	<input checked="" type="checkbox"/>	PHBHM16 	PHBHM16P 

Posi-Hex™ Ball Plungers - Steel w/Nylon Ball

Part No.			End Force, N		A	B	C	ØD	HEX	ROHS	CAD	CAD With Thread Lock
	With Thread Lock	Initial	Final									
DPHBM4	 DPHBM4P		4.0	10.0	M4 x 0.7	11.2	0.8	2.5	2.0	<input checked="" type="checkbox"/>	DPHBM4 	DPHBM4P 
DPHBM5	 DPHBM5P		8.0	14.0	M5 x 0.8	14.4	0.9	3.0	2.5	<input checked="" type="checkbox"/>	DPHBM5 	DPHBM5P 

DPHBHM5 	DPHBHM5P 	15.0	22.0	M5 x 0.8	14.4	0.9	3.0	2.5	<input checked="" type="checkbox"/>	DPHBHM5 	DPHBHM5P 
DPHBM6 	DPHBM6P 	9.0	13.0	M6 X 1.0	17.0	1.0	3.5	2.5	<input checked="" type="checkbox"/>	DPHBM6 	DPHBM6P 
DPHBHM6 	DPHBHM6P 	28.0	40.0	M6 X 1.0	17.0	1.08	3.5	2.5	<input checked="" type="checkbox"/>	DPHBHM6 	DPHBHM6P 
DPHBM8 	DPHBM8P 	15.0	30.0	M8 x 1.25	18.2	1.5	5.0	2.5	<input checked="" type="checkbox"/>	DPHBM8 	DPHBM8P 
DPHBLM8 	DPHBLM8P 	5.0	10.0	M8 x 1.25	18.2	1.5	5.0	2.5	<input checked="" type="checkbox"/>	DPHBLM8 	DPHBLM8P 
DPHBHM8 	DPHBHM8P 	40.0	60.0	M8 x 1.25	18.2	1.5	5.0	2.5	<input checked="" type="checkbox"/>	DPHBHM8 	DPHBHM8P 
DPHBM10 	DPHBM10P 	20.0	35.0	M10 x1.5	22.9	2.0	6.0	4.0	<input checked="" type="checkbox"/>	DPHBM10 	DPHBM10P 
DPHBLM10 	DPHBLM10P 	8.0	15.0	M10 x1.5	22.9	2.0	6.0	4.0	<input checked="" type="checkbox"/>	DPHBLM10 	DPHBLM10P 
DPHBHM10 	DPHBHM10P 	60.0	90.0	M10 x1.5	22.9	2.0	6.0	4.0	<input checked="" type="checkbox"/>	DPHBHM10 	DPHBHM10P 
DPHBM12 	DPHBM12P 	30.0	55.0	M12 x1.75	26.6	2.5	8.0	6.0	<input checked="" type="checkbox"/>	DPHBM12 	DPHBM12P 
DPHBLM12 	DPHBLM12P 	10.0	20.0	M12 x1.75	26.6	2.5	8.0	6.0	<input checked="" type="checkbox"/>	DPHBLM12 	DPHBLM12P 
DPHBHM12 	DPHBHM12P 	75.0	115.0	M12 x1.75	26.6	2.5	8.0	6.0	<input checked="" type="checkbox"/>	DPHBHM12 	DPHBHM12P 
DPHBM16 	DPHBM16P 	41.0	86.0	M16 x2.0	31.7	3.5	10.0	8.0	<input checked="" type="checkbox"/>	DPHBM16 	DPHBM16P 
DPHBLM16 	DPHBLM16P 	20.0	40.0	M16 x2.0	31.7	3.5	10.0	8.0	<input checked="" type="checkbox"/>	DPHBLM16 	DPHBLM16P 
DPHBHM16 	DPHBHM16P 	68.0	142.0	M16 x2.0	31.7	3.5	10.0	8.0	<input checked="" type="checkbox"/>	DPHBHM16 	DPHBHM16P 

Proud to be [ISO:50001](#) and [ISO:9001](#) Certified

Cage Code: 01226



Copyright © 2024 Vliet Inc. | All Rights Reserved | A Division of  HUTCHINSON®