

Leveling Devices

Original Series Stud Style with Delrin® Base Steel

Vlier's original series stud style leveling devices in steel feature a plastic Delrin® base that protects floors and surface finishes, and resists repeated impacts, moisture and temperatures up to 190°.









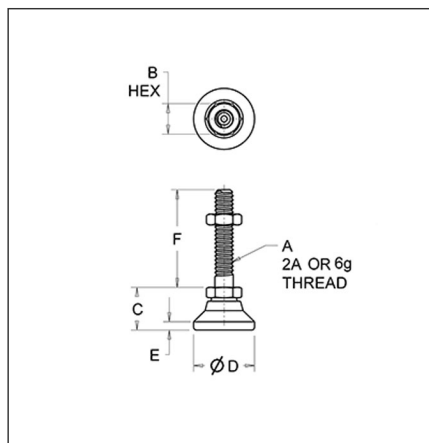

Typical Uses

- Data storage equipment
- Large medical equipment
- Material handling equipment
- Industrial workstations
- Industrial machines









Special Features

- Hardened ball
- Stud with integrally machined hex
- Long-life, high-impact Delrin® pad protects surface finish
- Large diameter base support
- 15° swivel off centerline



Part No.	Max Load (Lbs.)	A	B	C	D	E	F	ROHS	CAD
NP298S 	150	10-32	3/8	17/32	3/4	7/64	1	<input checked="" type="checkbox"/>	NP298S 
NP300S 	200	1/4-20	1/2	45/64	1	5/32	1-1/4	<input checked="" type="checkbox"/>	NP300S 
NP304S 	300	3/8-16	5/8	7/8	1-1/4	3/16	2	<input checked="" type="checkbox"/>	NP304S 
NP306S 	700	1/2-13	3/4	1-1/8	1-7/8	1/4	2	<input checked="" type="checkbox"/>	NP306S 
NP308S 	1,200	5/8-11	7/8	1-1/4	2-1/2	5/16	2	<input checked="" type="checkbox"/>	NP308S 
NP310S 	1,800	3/4-10	1-1/16	1-1/2	3	1/2	2	<input checked="" type="checkbox"/>	NP310S 
NP312S 	2,400	1-8	1-3/8	1-7/8	4	13/32	4-1/4	<input checked="" type="checkbox"/>	NP312S 

Original Series Stud Style w/Delrin® Base - Steel

Part No.	Max Load (kg.)	A	B	C	D	E	F	ROHS	CAD
NPM10S 	136	M10 x 1.5	17	22	32	5	51	<input checked="" type="checkbox"/>	NPM10S 
NPM12S 	318	M12 x 1.75	19	29	48	6	51	<input checked="" type="checkbox"/>	NPM12S 
NPM16S 	546	M16 x 2.0	24	32	64	8	51	<input checked="" type="checkbox"/>	NPM16S 
NPM20S 	818	M20 x 2.5	30	38	76	13	51	<input checked="" type="checkbox"/>	NPM20S 

Proud to be [ISO:50001](#) and ISO:9001 Certified
Cage Code: 01226



Copyright © 2024 Vliet Inc. | All Rights Reserved | A Division of  HUTCHINSON®