

Leveling Devices

Original Series Socket Style with Elastomer Pad Steel

Vlier's original series socket style leveling devices in steel feature an elastomer pad that provides a .125 inch neoprene elastomer bonded to the bottom of the base for non-skid support. For applications with an existing stud installation, the standard design is zinc plate with gold chromate finish.









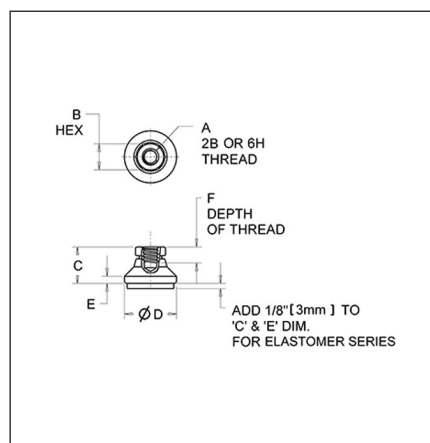





Typical Uses

- Data storage equipment
- Large medical equipment
- Material handling equipment
- Industrial workstations
- Industrial machines

Special Features

- Hardened ball
- Stud with integrally machined hex
- Large diameter base support
- 15° swivel off centerline



| Part No. | Max Load (Lbs.) | A | B | C | D | E | F | ROHS | CAD |
|--|-----------------|--------|--------|-------|-------|-------|-------|-------------------------------------|--|
| EP298B  | 525 | 10-32 | 3/8 | 17/32 | 3/4 | 7/64 | 15/64 | <input checked="" type="checkbox"/> | EP298B  |
| EP300B  | 800 | 1/4-20 | 1/2 | 45/64 | 1 | 5/32 | 5/16 | <input checked="" type="checkbox"/> | EP300B  |
| EP304B  | 2,800 | 3/8-16 | 5/8 | 7/8 | 1-1/4 | 3/16 | 3/8 | <input checked="" type="checkbox"/> | EP304B  |
| EP306B  | 3,750 | 1/2-13 | 3/4 | 1-1/8 | 1-7/8 | 1/4 | 7/16 | <input checked="" type="checkbox"/> | EP306B  |
| EP308B  | 4,500 | 5/8-11 | 7/8 | 1-1/4 | 2-1/2 | 5/16 | 7/16 | <input checked="" type="checkbox"/> | EP308B  |
| EP310B  | 5,400 | 3/4-10 | 1-1/16 | 1-1/2 | 3 | 1/2 | 5/8 | <input checked="" type="checkbox"/> | EP310B  |
| EP312B  | 16,400 | 1-8 | 1-3/8 | 1-7/8 | 4 | 13/32 | 13/16 | <input checked="" type="checkbox"/> | EP312B  |

Original Series Socket Style w/Elastomer Pad - Steel

| Part No. | Max Load (kg.) | A | B | C | D | E | F | ROHS | CAD |
|--|----------------|------------|----|----|----|----|------|-------------------------------------|--|
| EPM10B  | 1,273 | M10 x 1.5 | 17 | 22 | 32 | 5 | 9.6 | <input checked="" type="checkbox"/> | EPM10B  |
| EPM12B  | 1,750 | M12 x 1.75 | 19 | 29 | 48 | 6 | 11.0 | <input checked="" type="checkbox"/> | EPM12B  |
| EPM16B  | 2,046 | M16 x 2.0 | 24 | 32 | 64 | 8 | 11.0 | <input checked="" type="checkbox"/> | EPM16B  |
| EPM20B  | 2,455 | M20 x 2.5 | 30 | 38 | 76 | 13 | 15.7 | <input checked="" type="checkbox"/> | EPM20B  |

Proud to be [ISO:50001](#) and ISO:9001 Certified

Cage Code: 01226



Copyright © 2024 Vlier Inc. | All Rights Reserved | A Division of  HUTCHINSON®