

# Long Travel Hex Nose Plungers

## ANSI & Metric

Long travel hex nose plungers are ideal for high-speed, long-life applications. They are easily inserted, adjusted or removed with a standard wrench from plunger end.

## Typical Uses

- Positioning
- Indexing
- Ejecting
- With Thread Lock
- Latching
- Detents
- Contacts
- Lifters
- Insulators

## Special Features



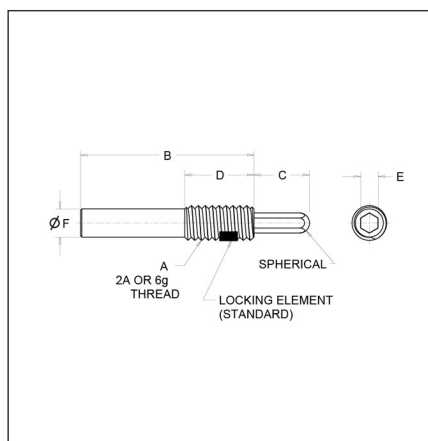

- Hexagonal nose design
- Case hardened plunger
- Steel, black oxide finish
- Standard thread lock











### Long Travel Hex Nose Plungers

Part No.	End Force, (Lbs.)		A	B	C	D	E	F	ROHS	CAD
	Initial	Final								
HH6251 	4.0	20.0	5/8-11	3.12	1.00	1.25	0.31	0.510	<input checked="" type="checkbox"/>	HH6251 
HH7501 	4.0	35.0	3/4-10	3.75	1.00	1.50	0.38	0.612	<input checked="" type="checkbox"/>	HH7501 
HH1000 	16.0	50 3/4	1-8	5.00	1.00	2.00	0.50	0.844	<input checked="" type="checkbox"/>	HH1000 
HH1015 	16.0	68.0	1-8	5.00	1.50	2.00	0.50	0.844	<input checked="" type="checkbox"/>	HH1015 





### Light End Force Long Travel Hex Nose Plungers

Part No.	End Force, (Lbs.)		A	B	C	D	E	F	ROHS	CAD
	Initial	Final								
HL1000 	4.0	22.0	1-8	5.00	1.00	2.00	0.50	0.844	<input checked="" type="checkbox"/>	HL1000 
HL1015 	4.0	31.0	1-8	5.00	1.50	2.00	0.50	0.844	<input checked="" type="checkbox"/>	HL1015 

### Long Travel Hex Nose Plungers

Part No.	End Force, N		A	B	C	D	E	F	ROHS	CAD
	Initial	Final								
HHM160 	17.8	89.0	M16x20	79.3	25.4	31.8	7.9	13.0	<input checked="" type="checkbox"/>	HHM160 
HHM200 	17.8	155.7	M20x2.5	95.3	25.4	38.1	9.7	15.8	<input checked="" type="checkbox"/>	HHM200 
HHM240 	71.2	225.7	M24x3.0	127.0	25.4	50.8	12.7	21.4	<input checked="" type="checkbox"/>	HHM240 
HHM245 	71.2	302.5	M24x3.0	127.0	38.1	50.8	12.7	21.4	<input checked="" type="checkbox"/>	HHM245 

### Light End Force Long Travel Hex Nose Plungers

Part No.	End Force, N		A	B	C	D	E	F	ROHS	CAD
	Initial	Final								
HLM240 	17.8	97.9	M24x3.0	127	25.4	50.8	12.7	21.4	<input checked="" type="checkbox"/>	HLM240 
HLM245 	17.8	137.9	M24x3.0	127	38.1	50.8	12.7	21.4	<input checked="" type="checkbox"/>	HLM245 

Proud to be [ISO:50001](#) and ISO:9001 Certified

Cage Code: 01226

