

Hi-Life™ Standard Spring Plungers

Hi-Life™ standard spring plungers are specially designed to take tough abuse during high-speed, long-life product applications. The design is offered in steel with a black oxide finish.







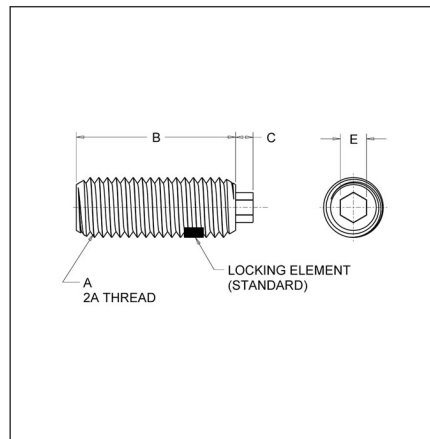

Typical Uses

- Positioning
- Indexing
- Ejecting
- With Thread Lock
- Latching
- Detents
- Contacts
- Lifters
- Insulators

Special Features

- Flat hexagonal nose design
- Long spring life
- Steel, black oxide finish
- Easy access & adjustment



Part No.	End Force, (Lbs.)		A	B	C	E	ROHS	CAD
	Initial	Final						
HT54N 	1/2	6 1/8	1/4-20	1.343	0.078	1/8	<input checked="" type="checkbox"/>	HT54N 
HT56N 	1/2	8	5/16-18	1.406	0.088	1/8	<input checked="" type="checkbox"/>	HT56N 
HT58N 	1/2	9 7/8	3/8-16	1.532	0.097	3/16	<input checked="" type="checkbox"/>	HT58N 
HT60N 	1/2	16	1/2-13	1.718	0.105	1/4	<input checked="" type="checkbox"/>	HT60N 

Product not available in metric.

Proud to be [ISO:50001](#) and [ISO:9001](#) Certified

Cage Code: 01226



Copyright © 2024 Vliet Inc. | All Rights Reserved | A Division of  | HUTCHINSON®