

## Contents

	<b>Page</b>
<b>1 2D Views</b>	<b>2</b>
<b>2 Configuration settings</b>	<b>3</b>
<b>3 Attachments / Technical document</b>	<b>4</b>
<b>4 Contact information</b>	<b>5</b>

# 1 2D Views

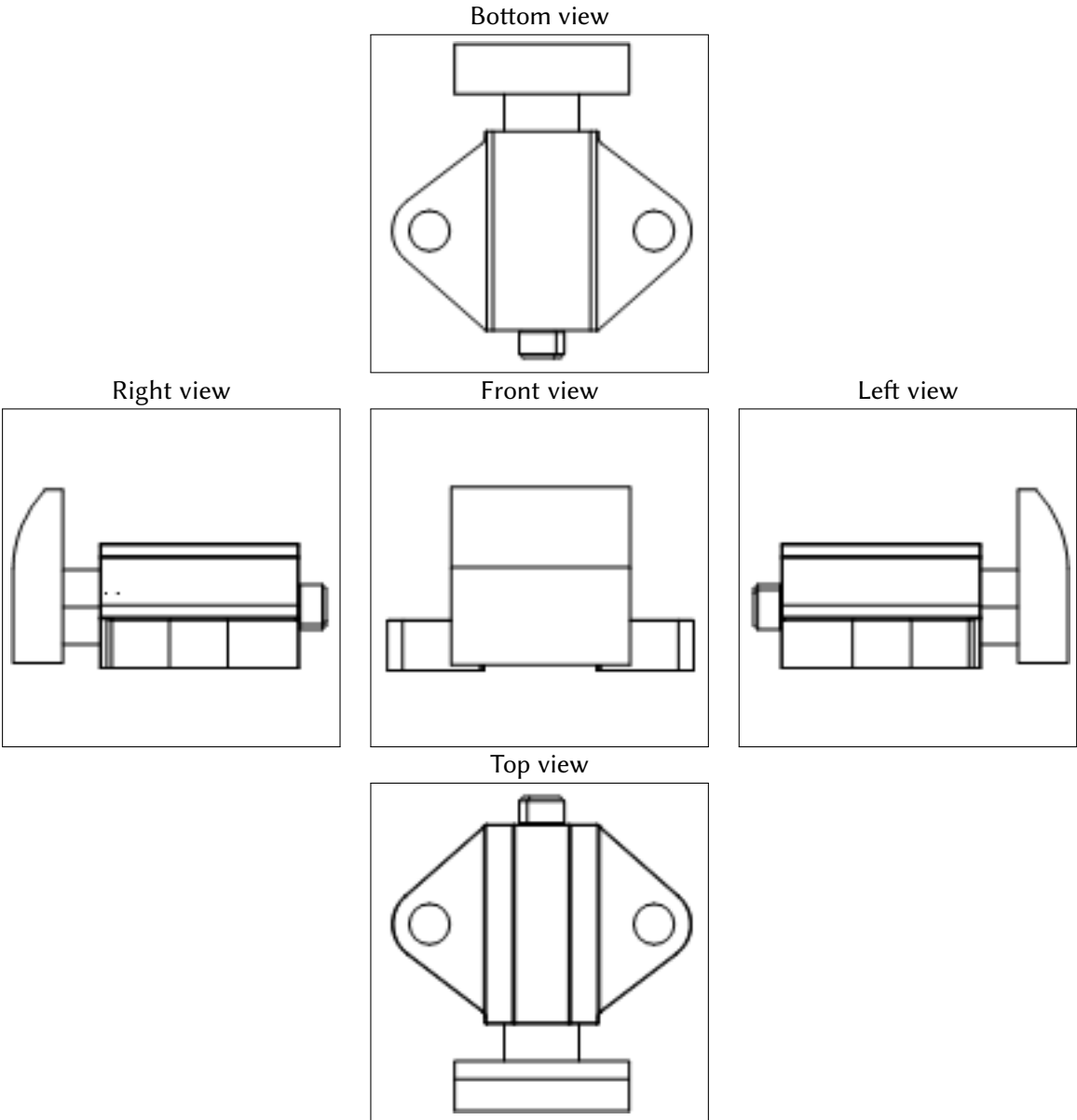



## 2 Configuration settings

Configuration	
Part Number	CL-20C-SSB
Description	Spring Stop Buttons – Flat Face (Type C), Standard Force, Steel Plunger
Base Part Number	CL-20C-SSB
Material	Aluminum
Nose Material	Steel
STROKE	3/16
INITIAL CONTACT FORCE (lbs)	2
HALFWAY CONTACT FORCE (lbs)	14
FINAL CONTACT FORCE (lbs)	26
A	1.125
B	1/2
C	15/16
D	3/4
E	1/4
F	5/16
G	# 10 or M5
L	1/4
M	7/8
N	9/32
P	7/8
R	3/32
Measurement	Universal

Bill of Materials Data	
Manufacturer	Carr Lane Manufacturing
Description	Spring Stop Buttons – Flat Face (Type C), Standard Force, Steel Plunger
Part Number	CL-20C-SSB
Material	Aluminum
Nose Material	Steel

### 3 Attachments / Technical document

Please double click with left mouse button on a paper clip symbol to open a file. You could also save a file when you click the symbol with the right mouse button.

- Product Page 
- Product Catalog 
- Product Drawing 



## 4 Contact information



Carr Lane  
4200 Carr Lane Ct.  
P.O. Box 191970  
63119-7970  
MO  
St Louis



[www.carrlane.com](http://www.carrlane.com)