

Ball Plungers

Steel

Ball plungers can take the highest degree of side load and provide repeatable force time and time again.









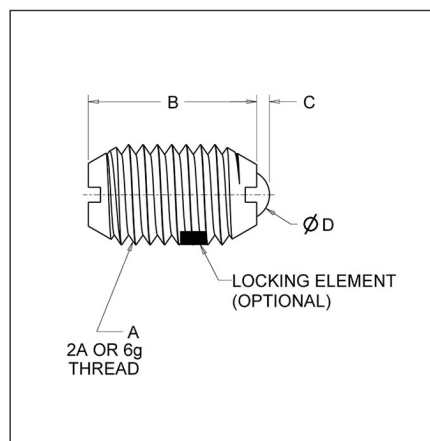



















































































Typical Uses

- Positioning
- Indexing
- Locating
- Torque limiting
- Gear shifters
- Detents

Special Features

- Smallest & lightest spring-loaded device
- Side-load tolerant
- Controlled end forces
- Screwdriver installation
- Electrical contact



Part No.		End Force, (Lbs.)		A	B	C	D	ROHS	CAD	CAD With Thread Lock
	With Thread Lock	Initial	Final							
B46	 B46P	 1/8	1/2	4-48	0.187	0.020	0.062	<input checked="" type="checkbox"/>	B46 	B46P 
B47	 B47P	 1/4	3/4	5-40	0.250	0.020	0.062	<input checked="" type="checkbox"/>	B47 	B47P 
B48	 B48P	 1/2	1.0	6-40	0.312	0.023	0.078	<input checked="" type="checkbox"/>	B48 	B48P 
B50A	 B50AP	 1/2	1-1/4	8-32	0.344	0.025	0.094	<input checked="" type="checkbox"/>	B50A 	B50AP 
B50	 B50P	 1/2	1-1/4	8-36	0.344	0.025	0.094	<input checked="" type="checkbox"/>	B50 	B50P 
B52	 B52P	 1-1/2	3.0	10-32	0.513	0.025	0.094	<input checked="" type="checkbox"/>	B52 	B52P 
BL52	 BL52P	 1/2	1-1/2	10-32	0.513	0.025	0.094	<input checked="" type="checkbox"/>	BL52 	BL52P 
BH52	 BH52P	 2.0	5.0	10-32	0.513	0.025	0.094	<input checked="" type="checkbox"/>	BH52 	BH52P 
B54	 B54N	 3.0	7.0	1/4-20	0.531	0.035	0.125	<input checked="" type="checkbox"/>	B54 	B54N 
BL54	 BL54N	 2.0	4.0	1/4-20	0.531	0.035	0.125	<input checked="" type="checkbox"/>	BL54 	BL54N 
BH54	 BH54N	 4.0	12.0	1/4-20	0.531	0.035	0.125	<input checked="" type="checkbox"/>	BH54 	BH54N 
B56	 B56N	 4.0	9.0	5/16-18	0.578	0.040	0.156	<input checked="" type="checkbox"/>	B56 	B56N 
BL56	 BL56N	 2.0	4-1/4	5/16-18	0.578	0.040	0.156	<input checked="" type="checkbox"/>	BL56 	BL56N 
BH56	 BH56N	 6.0	17.0	5/16-18	0.578	0.040	0.156	<input checked="" type="checkbox"/>	BH56 	BH56N 
B58	 B58N	 5.0	10.0	3/8-16	0.625	0.048	0.188	<input checked="" type="checkbox"/>	B58 	B58N 
BL58	 BL58N	 2-1/5	5.0	3/8-16	0.625	0.048	0.188	<input checked="" type="checkbox"/>	BL58 	BL58N 
BH58	 BH58N	 6.0	21.0	3/8-16	0.625	0.048	0.188	<input checked="" type="checkbox"/>	BH58 	BH58N 
B60	 B60N	 6.0	12.0	1/2-13	0.750	0.072	0.281	<input checked="" type="checkbox"/>	B60 	B60N 
BL60	 BL60N	 3.0	6.0	1/2-13	0.750	0.072	0.281	<input checked="" type="checkbox"/>	BL60 	BL60N 
BH60	 BH60N	 6.0	30.0	1/2-13	0.750	0.072	0.281	<input checked="" type="checkbox"/>	BH60 	BH60N 
B62	 B62N	 9.0	18.0	5/8-11	0.984	0.096	0.375	<input checked="" type="checkbox"/>	B62 	B62N 
BL62	 BL62N	 4-1/2	9.0	5/8-11	0.984	0.096	0.375	<input checked="" type="checkbox"/>	BL62 	BL62N 
BH62	 BH62N	 7.0	50.0	5/8-11	0.984	0.096	0.375	<input checked="" type="checkbox"/>	BH62 	BH62N 

Ball Plungers - Steel

Part No.		End Force, N		A	B	C	D	ROHS	CAD	CAD With Thread Lock
	With Thread Lock*	Initial	Final							

BM3A		BM3AP		3.0	4.5	M3 x 0.5	7.0	0.4	1.5	<input checked="" type="checkbox"/>	BM3A		BM3AP	
BM4A		BM4AP		4.0	10.0	M4 x 0.7	9.0	0.8	2.5	<input checked="" type="checkbox"/>	BM4A		BM4AP	
BM5A		BM5AP		8.0	14.0	M5 x 0.8	12.0	0.9	3.0	<input checked="" type="checkbox"/>	BM5A		BM5AP	
BMH5A		BMH5AP		15.0	22.0	M5 x 0.8	12.0	0.9	3.0	<input checked="" type="checkbox"/>	BMH5A		BMH5AP	
BM6A		BM6AP		9.0	13.0	M6 x 1.0	14.0	1.0	3.5	<input checked="" type="checkbox"/>	BM6A		BM6AP	
BML6A		BML6AP		2.0	6.0	M6 x 1.0	14.0	1.0	3.5	<input checked="" type="checkbox"/>	BML6A		BML6AP	
BMH6A		BMH6AP		28.0	40.0	M6 x 1.0	14.0	1.0	3.5	<input checked="" type="checkbox"/>	BMH6A		BMH6AP	
BM8A		BM8AN		15.0	30.0	M8 x 1.25	16.0	1.5	5.0	<input checked="" type="checkbox"/>	BM8A		BM8AN	
BML8A		BML8AN		5.0	10.0	M8 x 1.25	16.0	1.5	5.0	<input checked="" type="checkbox"/>	BML8A		BML8AN	
BMH8A		BMH8AN		40.0	60.0	M8 x 1.25	16.0	1.5	5.0	<input checked="" type="checkbox"/>	BMH8A		BMH8AN	
BM10A		BM10AN		20.0	35.0	M10 x 1.5	19.0	2.0	6.0	<input checked="" type="checkbox"/>	BM10A		BM10AN	
BML10A		BML10AN		8.0	15.0	M10 x 1.5	19.0	2.0	6.0	<input checked="" type="checkbox"/>	BML10A		BML10AN	
BMH10A		BMH10AN		60.0	90.0	M10 x 1.5	19.0	2.0	6.0	<input checked="" type="checkbox"/>	BMH10A		BMH10AN	
BM12A		BM12AN		30.0	55.0	M12 x 1.75	22.0	2.5	8.0	<input checked="" type="checkbox"/>	BM12A		BM12AN	
BML12A		BML12AN		10.0	20.0	M12 x 1.75	22.0	2.5	8.0	<input checked="" type="checkbox"/>	BML12A		BML12AN	
BMH12A		BMH12AN		75.0	115.0	M12 x 1.75	22.0	2.5	8.0	<input checked="" type="checkbox"/>	BMH12A		BMH12AN	
BM16A		BM16AN		41.0	86.0	M16 x 2.0	24.0	3.5	10.0	<input checked="" type="checkbox"/>	BM16A		BM16AN	
BMH16A		BMH16AN		68.0	142.0	M16 x 2.0	24.0	3.5	10.0	<input checked="" type="checkbox"/>	BMH16A		BMH16AN	

Proud to be [ISO:50001](#) and ISO:9001 Certified

Cage Code: 01226



Copyright © 2024 Vliet Inc. | All Rights Reserved | A Division of  HUTCHINSON®