

Ball Buttons

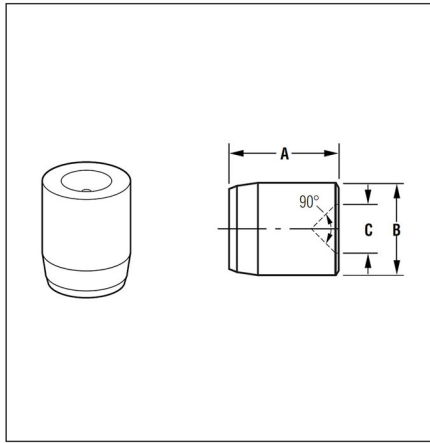

Ball buttons can be easily pushed into a reamed hole to provide the perfect ball plunger mating detent. They prevent part damage and provide a hardened striker plate to take the wear and tear of side loads.













Special Features

- Chamfered end for easy insertion
- 440C stainless steel, hardened & ground



Ball Buttons

Part No.	For Ball Plungers	A	B		C	ROHS	CAD
			+0.0002	-0.000			
BB46	 SSB46, SSB47, DSSB46, DSSB437, B46, B47	1/8	0.1075	0.056	<input checked="" type="checkbox"/>	 BB46	

BB48		SSB48, DSSB48, B48	1/8	0.1175	0.061	<input checked="" type="checkbox"/>	BB48 
BB50		B52, BM4, BM6, BL52, BH52, BML6, MBH6, SSB50, SSB52, SSBL52, SSBH52, DSSB50, 50A, 52	3/16	0.1614	0.069	<input checked="" type="checkbox"/>	BB50 
BB54		SSB54, SSBL54, SSBH54, D54N, D54, DSSB Series	1/4	0.2034	0.111	<input checked="" type="checkbox"/>	BB54 
BB56		B56, BM8, BMH8, BML8, BL56, BH56, SSB56, SSBH56, D56, DL56, ND56, NDL56, DSSB Series	5/16	0.2659	0.139	<input checked="" type="checkbox"/>	BB56 
BB58		BM10, BML10, BMH10, B58, BL58, BH58, SSB58, SSBL58, SSBH58, D58, DL58, ND58, NDL58, DSSB Series	3/8	0.3284	0.164	<input checked="" type="checkbox"/>	BB58 
BB60		B60, BL60, BH60, BM12, BMH12, BML12, SSB60, SSBL60, SSBH60, DSSB Series	1/2	0.4378	0.241	<input checked="" type="checkbox"/>	BB60 
BB62		B62, BL62, BH62, SSBH62, SSBL62, SSB62	5/8	0.5472	0.330	<input checked="" type="checkbox"/>	BB62 

Product not available in metric.

Proud to be [ISO:50001](#) and ISO:9001 Certified

Cage Code: 01226



Copyright © 2024 Vlier Inc. | All Rights Reserved | A Division of  | HUTCHINSON®