

Quarter Turn T-Slot Nuts

- Sintered Metal
- The last thread is incomplete to prevent the stud from turning through the bottom of the nut
- Special sizes quoted upon request

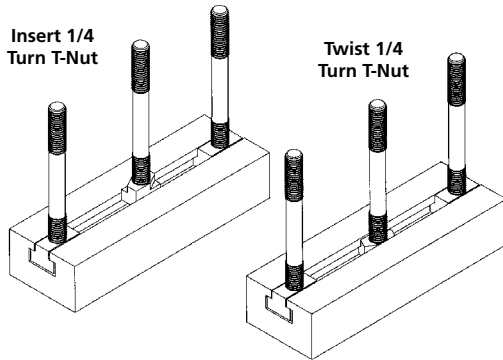
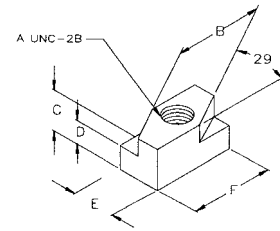

Part No.	Thread A	English Table Slot B	Metric Table Slot	C	D	E	F	Weight (lbs/100pcs)
41450	3/8-16	7/16	12MM	1/2	0.208	0.438	0.75	2.7
41451	3/8-16	1/2	12MM	1/2	0.271	0.500	1	4.6
41452	1/2-13	9/16	15MM	5/8	0.333	0.563	0.94	5.3
41453	1/2-13	5/8	16MM	5/8	0.333	0.625	1.25	8.9
41454	5/8-11	11/16	18MM	3/4	0.427	0.688	1.38	11.9
41455	5/8-11	3/4	20MM	3/4	0.458	0.75	1.50	15.7
41456	1/2-13	11/16	18MM	3/4	0.427	0.688	1.3	14.2
41457	3/4-10	1	26MM	1	0.615	1	1.75	33.6

Quarter Turn T-Nut Application

* Quarter Turn T-Slot Nuts are undersized to fit machine table slot

Flange Nuts

- Black oxide finish, case hardened
- 12L14 Material
- Available in Coarse or Fine Threads
- **Standard package quantity:**
41601- 41607: 25 pcs.
41701- 41707: 25 pcs.
- Many sizes conform to TCMAI standards
- Special sizes quoted upon request
- Metric: Dimension in millimeters



UNC Flange Nuts

Part No.	Thread A	B	C	D	E	Weight (lbs/100pcs)
41601	1/4-20	5/8	5/16	3/32	1/2	3
41602	5/16-18	3/4	3/8	1/8	9/16	4
41603	3/8-16	7/8	1/2	1/8	11/16	5
41604	7/16-14	1	9/16	5/32	3/4	7
41605	1/2-13	1-1/8	11/16	3/16	7/8	11
41606	5/8-11	1-3/8	13/16	3/16	1-1/16	18
41607	3/4-10	1-5/8	1	1/4	1-1/4	31
41608	7/8-9	1-3/4	1-1/8	1/4	1-7/16	42
41609	1-8	2	1-1/4	1/4	1-5/8	59
41611	1-1/4 -7	2-1/2	1-1/4	1/4	1-13/16	66

UNF Flange Nuts

Part No.	Thread A	B	C	D	E	Weight (lbs/100pcs)
41701	1/4-28	5/8	5/16	3/32	1/2	3
41702	5/16-24	3/4	3/8	1/8	9/16	4
41703	3/8-24	7/8	1/2	1/8	11/16	5
41704	7/16-20	1	9/16	5/32	3/4	7
41705	1/2-20	1-1/8	11/16	3/16	7/8	11
41706	5/8-18	1-3/8	13/16	3/16	1-1/16	18
41707	3/4-16	1-5/8	1	1/4	1-1/4	31
41708	7/8-14	1-3/4	1-1/8	1/4	1-7/16	42
41709	1-14	2	1-1/4	1/4	1-5/8	59

Metric

Part No.	Thread A	B	C	D	E	Weight (lbs/100pcs)
61601	M6 x 1.0	16	8	2	10	1.8
61602	M8 x 1.25	19	10	2.5	13	2.4
61603	M10 x 1.5	22	13	3	17	3.5
61604	M12 x 1.75	27	17	4	19	9.5
61605	M16 x 2.0	33	21	5	24	16.5
61606	M20 x 2.5	40	25	6	30	29
61607	M24 x 3.0	49	32	7	36	51

