

**OPERATING & MAINTENANCE INSTRUCTIONS
FOR SIMPLEX TANK JACKS
MODEL 4406, 4410, 4416, & 4418**

IMPORTANT: PRIOR TO USING JACK, READ AND UNDERSTAND JACK OPERATING INSTRUCTIONS BELOW AND SAFETY PRECAUTIONS OUTLINED ON THE REVERSE SIDE. FOLLOW THESE INSTRUCTIONS AND PROCEDURES AS APPLICABLE.

IN ADDITION, THE OPERATOR SHOULD ADHERE TO THE GENERAL SAFETY PRINCIPLES AND ACCIDENT PREVENTATIVE MEASURES AS OUTLINED BY THE EQUIPMENT OWNER OR OTHER PREVAILING AUTHORITY.

JACK OPERATING INSTRUCTIONS:

THE SIMPLEX SADDLE, ILLUSTRATED BELOW AND REFERENCED IN THE TABLE, IS TO BE USED WITH EACH JACK. PRIOR TO PLACING TANK ONTO JACKS, WELD THE SADDLES TO THE TANK IN A MANNER TO GIVE PROPER STABILITY AND PROVIDE EQUAL DISTRIBUTION OF THE LOAD TO ALL JACKS (SEE SIMPLEX CATALOG FOR GENERAL APPLICATION SUGGESTIONS AND TYPICAL SADDLE LOCATIONS). PRE-ADJUST EACH JACK HEIGHT BY TURNING THE LOAD SCREW UNTIL JACK LOAD POINTS ARE REASONABLY LEVEL.

PLACE THE JACKS IN TRUE POSITION AND INSTALL THE TANK MAKING SURE THAT THE LOAD POINT OF EACH JACK IS PROPERLY ALIGNED WITH THE LOAD POINT OF EACH SADDLE. CAUTION: PRIOR TO OPERATING THE JACK TO LEVEL THE LOAD SAFETY CONSTRAINTS SHOULD BE INSTALLED IN A MANNER THAT THE JACK CANNOT SLIP AND THE LOAD CANNOT SHIFT OR FALL.

INSERT A 3/8 DIA. LEVER BAR THRU THE HOLE IN THE LOAD SCREW AND APPLY TORQUE TO EXTEND OR RETRACT THE LOAD SCREW. GRIP THE BAR FIRMLY, EXERTING A CONTROLLED FORCE. TURNING THE SCREW TO MOVE THE LOAD AT EACH JACK UNTIL PROPER LEVEL IS ACHIEVED.

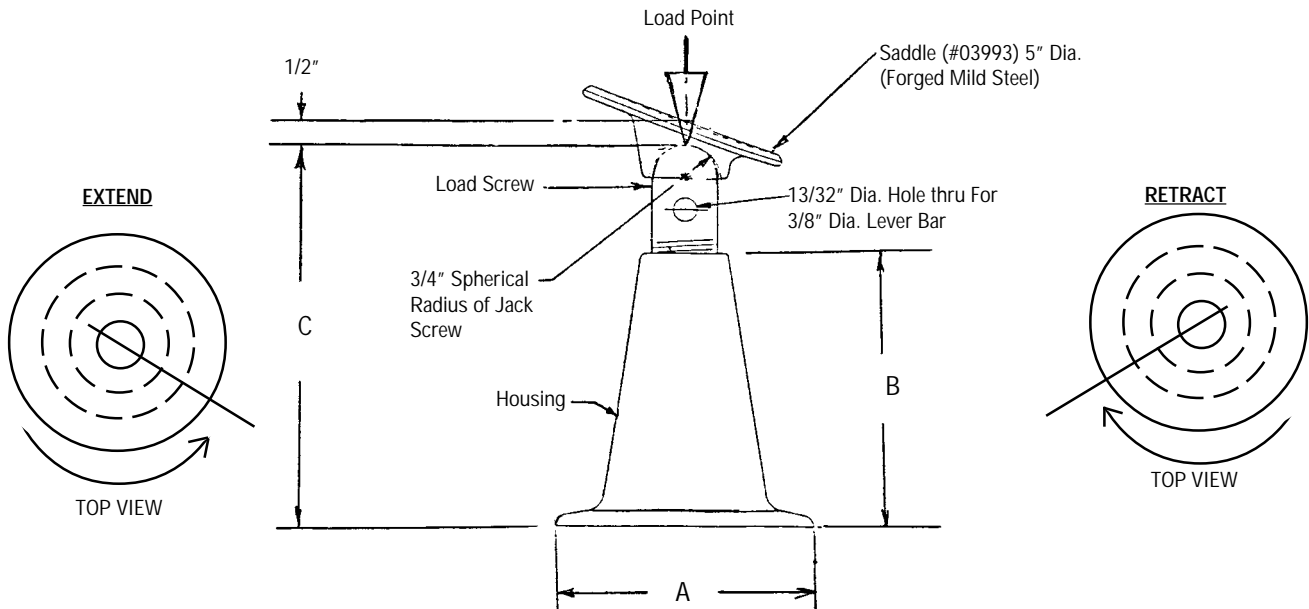

JACK ITEM NO.	JACK MODEL NO.	SADDLE ITEM NO.	A in.	B in.	DIMENSION C		JACK CAPACITY (LBS.)
					CLOSED HEIGHT	MAXIMUM ALLOWABLE EXTENDED HEIGHT (SEE WARNING ABOVE)	
4406	03820	03993	5 3/4	4	6	8	15,000
4410	03840	03993	6	8	10	12	15,000
4414	03860	03993	6 1/2	12	14	16	15,000
4418	03880	03993	8	16	18	20	15,000

***PERMANENTLY MARKED ON JACK HOUSING**

SAFE PROCEDURES & SAFETY PRECAUTIONS:

1. PRIOR TO USE, THE OPERATOR SHOULD BE INSTRUCTED BY A QUALIFIED PERSON IN THE SAFE AND PROPER USE OF THE JACK FOR ANY SPECIFIC APPLICATION.
NOTICE: TEMPLETON, KENLY & CO. MAKES NO WARRANTY THAT THE JACKS COVERED BY THIS DOCUMENT ARE SUITABLE FOR ANY GENERAL OR PARTICULAR USE EXCEPT LEVELING TANKS AND THE USER ASSUMES ALL LIABILITY ARISING THEREFROM.
2. IN ADDITION TO COMPLIANCE WITH GENERAL SAFETY PRINCIPLES AND ACCIDENT PREVENTATIVE INSTRUCTIONS NOTED ON THE REVERSE SIDE, ALL JACKS SHOULD BE VISUALLY CHECKED BY A QUALIFIED PERSON PRIOR TO EACH USE FOR DEFECTS, DAMAGE, PROPER LUBRICATION, AND WEAR. THE JACK SHOULD BE OPERATED PRIOR TO APPLICATION OF LOAD TO VERIFY THAT ALL MECHANISMS PROPERLY FUNCTION, AND THE JACK IS IN GOOD WORKING CONDITION. NEVER USE A JACK THAT IS DAMAGED, IMPROPERLY LUBRICATED, OR MALFUNCTIONING. JACKS THAT FAIL INSPECTION MUST BE REMOVED FROM SERVICE UNTIL REPAIRED BY AN AUTHORIZED AGENCY.
3. VERIFY THAT JACK CAPACITY AND TRAVEL IS SUITABLE FOR THE LOAD (SEE TABLE ON REVERSE SIDE).
4. MAKE SURE THAT THE JACK AND TANK SADDLE SUPPORTS ARE PROPERLY INSTALLED AND SECURELY WELDED (SEE OPERATING INSTRUCTIONS ON REVERSE SIDE).
5. **CHECK TO MAKE SURE THAT THE LEVER BAR TO BE USED FOR OPERATING JACK IS OF PROPER SIZE AND STRENGTH TO SAFELY OPERATE THE LOAD SCREW WITHOUT SLIPPING OR BENDING.**
6. PRIOR USE, THE OPERATOR SHOULD MAKE SURE THAT THE AREA IS CLEAR OF PERSONNEL AND OBJECTS OBSTRUCTING WORKSPACE REQUIRED TO SAFELY ACTIVATE THE LEVER IN BOTH DIRECTIONS. THE OPERATOR SHOULD ALSO CHECK THE CONDITION OF TANK SAFETY STABILIZERS AND MAKE CERTAIN THAT NECESSARY CONSTRAINTS ARE INSTALLED IN A MANNER TO PREVENT THE TANK FROM FALLING IN THE EVENT JACKS ARE ACCIDENTALLY DISLODGED DURING LEVELING OPERATION.
7. PRIOR TO OPERATING THE JACK TO APPLY LOAD, READ OPERATING INSTRUCTIONS ON THE REVERSE SIDE. APPLY TORQUE CAUTIOUSLY, TAKING CARE THAT THE JACK MAINTAINS PROPER ALIGNMENT AND OBSERVE DURING OPERATION FOR POSSIBLE SLIPPAGE OR SHIFT OF LOAD, (SEE CAUTION IN OPERATING INSTRUCTIONS ON THE REVERSE SIDE).
8. CAUTION: WHILE OPERATING TO EXTEND OR RETRACT THE LOAD, KEEP ALL PARTS OF THE HUMAN BODY CLEAR OF AREAS WHERE SERIOUS INJURY COULD OCCUR.
9. DO NOT EXCEED SAFE EXTENSION OF LOAD SCREW. DO NOT CONTINUE TURNING SCREW AFTER TRAVEL LIMIT IS REACHED. DO NOT APPLY EXCESSIVE TORQUE TO OVERLOAD THE JACK. DO NOT STRIKE WITH A HAMMER OR FORCE THE LEVER BAR IN A ROCKING MOTION. SUCH ACTIONS COULD DISLODGE THE JACK CREATING A PERSONAL INJURY.
10. A LOAD SHOULD NEVER BE ALLOWED TO REMAIN PERMANENTLY SUPPORTED OR RETAINED BY JACKS ONLY. AFTER LEVELING IS COMPLETE, THE LOAD SHOULD BE PERMANENTLY SECURED OR FIXED SUPPORTS SHOULD BE INSTALLED.
11. **CAUTION:** DO NOT ALLOW PERSONNEL ON OR UNDER LOADS UNTIL LEVELING IS COMPLETE AND THE LOAD IS SECURE WITH PROPER LOAD SUPPORTS AND FIXED RETAINERS INSTALLED IN ACCORDANCE WITH OSHA SAFETY AND HEALTH STANDARDS, AND THAT SUPPORTS, OR RETAINERS, HAVE BEEN INSPECTED AND APPROVED BY A SAFETY ENGINEER OR QUALIFIED PERSON OF AUTHORITY.

MAINTENANCE & LUBRICATION INSTRUCTIONS:

1. COMPLY WITH PROCEDURE #2 ABOVE AND PERFORM MAINTENANCE AND LUBRICATION AS DETERMINED FROM USE, EXPERIENCE OR AS SPECIFIED BY A QUALIFIED PERSON OF AUTHORITY.
2. KEEP JACK CLEAN, FREE OF GRIT, AND IN GOOD WORKING CONDITION.
3. LUBRICATE ALL LOAD SCREW THREADS WITH #2 GRAPHITE GREASE.

REF. SIMPLEX REPAIR PARTS:

PARTS SHEET #54101