

**PSC 4 Pole**

60 psi max. pressure, 2.4 CFM open flow (60 Hz)

PSC 2 Pole

60 psi max. pressure, 3.8 CFM open flow (60 Hz)

PSC 4 Pole Two Stage

25.5 inHg max. vacuum, 2.2 CFM open flow (60 Hz)

PSC 2 Pole Two Stage

25.5 inHg max. vacuum, 3.6 CFM open flow (60 Hz)

PSC 4 Pole Two Stage

29.0 inHg max. vacuum, 1.15 CFM open flow (60 Hz)

PSC 2 Pole Two Stage

29.0 inHg max. vacuum, 2.0 CFM open flow (60 Hz)

PRODUCT FEATURES

- Oilless operation
- Motor mounted
- Rugged construction/low maintenance

INCLUDES

- Muffler AH190A for vacuum
- Capacitor AF876 (EB motors), AF873A (ED motors), AF485A (GB and GD motors)

RECOMMENDED ACCESSORIES

- Pressure gauge AF583 / Vacuum gauge AA640
- Pressure relief valve AF887 / Vacuum relief valve AA550C-V
- Rubber feet (4) AF584A
- Repair kit K294A (use 2)

Product Dimensions (inches, mm)

Reference only

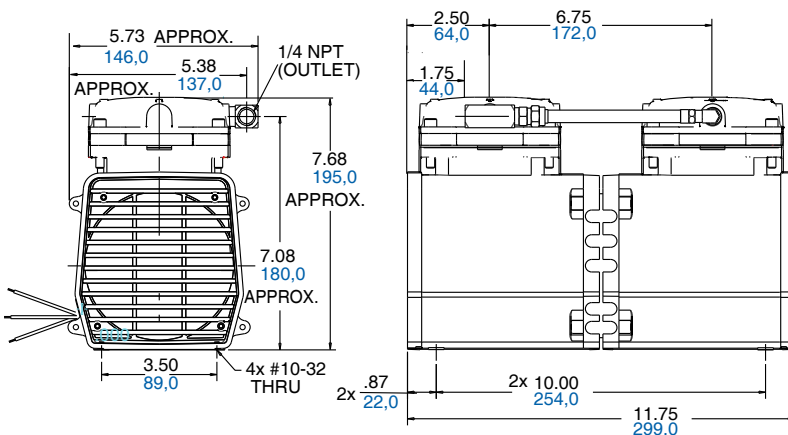

Product Specifications

Note: "P" model are pressure; "V" models are vacuum only

Model Number	Motor	Motor Type Stages for Vacuum Models	RPM		HP	kW	Net Weight		Regulatory
			60 Hz	50 Hz			lbs	kg	
DAA-P501-EB	115/110-60/50-1	PSC (4 pole)	1575	1275	1/4	0,19	28	12,7	cUR/CE
DAA-P501-ED	230/220-60/50-1	PSC (4 pole)	1575	1275	1/4	0,19	28	12,7	cUR/CE
*DAA-P517-ED	230/220-60/50-1	PSC (4 pole)	1575	1275	1/4	0,19	28	12,7	cUR/CE
**DAA-P513-EG	240-50-1	PSC (4 pole)	-----	1275	1/4	0,19	28	12,7	CE
***DAA-P501-GB	115/110-60/50-1	PSC (2 pole)	3000	2500	1/2	0,37	28	12,7	cUR
+DAA-P503-GB	115/110-60/50-1	PSC (2 pole)	3000	2500	1/2	0,37	28	12,7	cUR/CE
***DAA-P501-GD	230/220-60/50-1	PSC (2 pole)	3000	2500	1/2	0,37	28	12,7	cUR/CE
+DAA-P503-GD	230/220-60/50-1	PSC (2 pole)	3000	2500	1/2	0,37	28	12,7	cUR/CE
++DAA-P512-GD	230/220-60/50-1	PSC (2 pole)	3000	2500	1/2	0,37	28	12,7	cUR/CE
DAA-V505-EB	115/110-60/50-1	PSC (4 pole) single stage	1575	1275	1/4	0,19	23	10,4	cUR
DAA-V502-EB	115/110-60/50-1	PSC (4 pole) two stage	1575	1275	1/4	0,19	23	10,4	cUR/CE
DAA-V505-ED	230/220-60/50-1	PSC (4 pole) single stage	1575	1275	1/4	0,19	23	10,4	cUR/CE
DAA-V502-ED	230/220-60/50-1	PSC (4 pole) two stage	1575	1275	1/4	0,19	23	10,4	cUR
**DAA-V510-EG	240-50-1	PSC (4 pole) two stage	-----	1275	1/4	0,19	23	10,4	CE
DAA-V505-GB	115/110-60/50-1	PSC (2 pole) single stage	3000	2500	1/2	0,37	23	10,4	cUR
DAA-V507-GB	115/110-60/50-1	PSC (2 pole) two stage	3000	2500	1/2	0,37	23	10,4	cUR
DAA-V505-GD	230/220-60/50-1	PSC (2 pole) single stage	3000	2500	1/2	0,37	23	10,4	cUR/CE
DAA-V507-GD	230/220-60/50-1	PSC (2 pole) two stage	3000	2500	1/2	0,37	23	10,4	cUR/CE

- * Available only in Europe capacitor mounted on unit in mini-box. (European color-coded), no plug
- ** Capacitor mounted on unit in mini-box, two meter cord (European color-coded), no plug
- *** No capacitor, parallel manifold for pressure (single stage only)
- + Capacitor unattached, parallel manifold for pressure (single stage only)
- ++ Capacitor attached, parallel manifold for pressure (single stage only)

- CSA – Approved by the Canadian Standards Association
- cUR – UL recognized for use in Canada and US
- CNL – UL listed for use in Canada and US
- CE – Conforms to European Standards
- UL – UL Listed for US
- UR – UL recognized for US

Product Performance

Single Stage

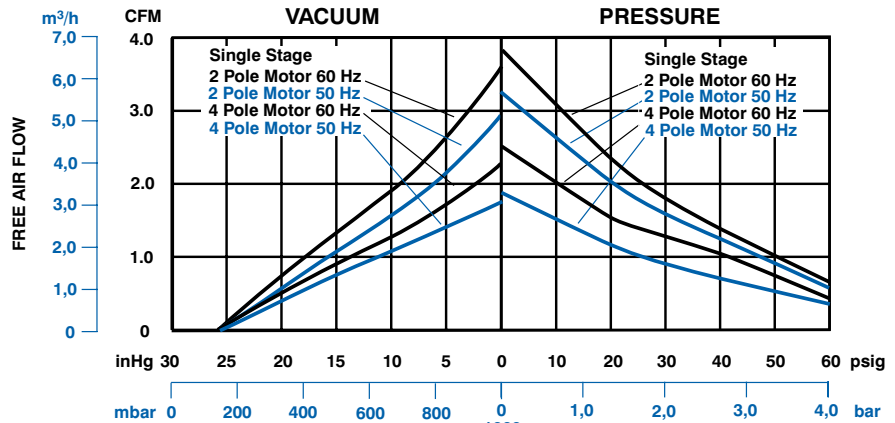

Two Stage

