

31, 32, 33 & 34 SERIES OIL-LESS VACUUM PUMPS & COMPRESSORS

OPERATION & MAINTENANCE MANUAL



Model 1031-102A Shown



Model 1531-107B Shown



Model 1532-101 Shown

Thank you for purchasing this Gast product. It is manufactured to the highest standards using quality materials. Please follow all recommended maintenance, operational and safety instructions and you will receive years of trouble free service.

IMPORTANT: PLEASE READ THIS MANUAL AND SAVE FOR FUTURE REFERENCE.

General information

- **Clearances:** Top: .001"
Ends: .0005" - .0010"
- **Vane Life:** 6,000 – 27,000 hours depending upon application
- **Model numbers ending in "X"** have automatic thermal protectors which protect the motor by shutting the motor off if it overheats. The motor will automatically restart once the motor has cooled.

Product Use Criteria:

- Pump only clean, dry air.
- Operate at 32°F - 104°F (0°C - 40°C).
- Protect unit from dirt & moisture.
- Do not pump flammable or explosive gases or use in an atmosphere that contains such gases.
- Protect all surrounding items from exhaust air. This exhaust air can become very hot.
- Corrosive gases and particulate material will damage unit. Water vapor, oil-based contaminants or other liquids must be filtered out.
- Consult your Gast Distributor/Representative before using at high altitudes.
- Oil-Less rotary-vanes require NO lubrication.
- Sealed bearings are grease packed.
- Use of petroleum or hydrocarbon products will reduce carbon vane service life.



ISO 9001 & 14001 CERTIFIED

www.gastmfg.com

Your safety and the safety of others is extremely important.

We have provided many important safety messages in this manual and on your product. Always read and obey all safety messages.



This is the safety alert symbol. This symbol alerts you to hazards that can kill or hurt you and others. The safety alert symbol and the words “DANGER” and “WARNING” will precede all safety messages. These words mean:

DANGER

You **will** be killed or seriously injured if you don't follow instructions.

WARNING

You **can** be killed or seriously injured if you don't follow instructions.

All safety messages will identify the hazard, tell you how to reduce the chance of injury, and tell you what can happen if the safety instructions are not followed.

INSTALLATION

WARNING



Electrical Shock Hazard

Disconnect electrical power at the circuit breaker or fuse box before installing this product.

Install this product where it will not come into contact with water or other liquids.

Install this product where it will be weather protected.

Electrically ground this product.

Failure to follow these instructions can result in death, fire or electrical shock.

Correct installation is your responsibility. Make sure you have the proper installation conditions and that installation clearances do not block air flow.

Blocking air flow over the product in any way can cause the product to overheat.

Mounting

This product can be installed in any orientation. Mounting the product to a stable, rigid operating surface and using shock mounts will reduce noise and vibration.

Plumbing

Remove plugs from the IN and OUT ports. Connect with pipe and fittings that are the same size or larger than the product's threaded ports.

Accessories

The product's internal intake and exhaust filters will provide adequate filtration in most applications. Check filters periodically and replace when necessary. The 32 and 34 Series models have internal intake and exhaust filters. Some models in the 31 and 33 Series have external intake and exhaust filters. All units should have an intake and exhaust filter to prevent contaminants from entering the pump or the pneumatic system. Please consult your Gast Distributor/Representative for additional filter recommendations.

Install relief valves and gauges at inlet or outlet, or both, to monitor performance. Check valves may be required to prevent back streaming through the pump.

Motor Control

It is your responsibility to contact a qualified electrician and assure that the electrical installation is adequate and in conformance with all national and local codes and ordinances.

Determine the correct overload setting required to protect the motor (see motor starter manufacturer's recommendations). Select fuses, motor protective switches or thermal protective switches to provide protection. Fuses act as short circuit protection for the motor, not as protection against overload. Incoming line fuses help to withstand the motor's starting current. Motor starters with thermal magnetic overload or circuit breakers protect motor from overload or reduced voltage conditions.

The wiring diagram supplied with the product provides required electrical information. Check that power source is correct to properly operate the dual-voltage motors.

Electrical Connection

Brush type DC motors will need replacement brushes after 500 hours to 1500 hours of operation. Contact your Gast Distributor/Representative for replacement brushes. Positive leads are **red** (+) and negative leads are **black** (-).

Brushless DC motors with controls are preset from the factory for single direction, uni-speed operation. Positive leads are **red** (+) and negative leads are **black** (-).

MFD and voltage ratings required for capacitors vary with motor. If you are unsure of what capacitor is required for your motor, contact your Gast Distributor/Representative.

OPERATION

WARNING

Injury Hazard

Product surfaces become very hot during operation, allow product surfaces to cool before handling.

Air stream from product may contain solid or liquid material that can result in eye or skin damage, wear proper eye protection.

Failure to follow these instructions can result in burns, eye injury or other serious injury.

It is your responsibility to operate this product at recommended pressures or vacuum duties and room ambient temperatures.

Model numbers ending in "X" have automatic thermal protectors which protect the motor by shutting the motor off if it overheats. The motor will automatically restart once the motor has cooled.

Start Up

If motor fails to start or slows down significantly under load, shut off and disconnect from power supply. Check that the voltage is correct for motor and that motor is turning in the proper direction. Vane life will be drastically reduced if motor is not operating properly. Vanes can break or be damaged if motor/pump runs in the wrong direction.

MAINTENANCE

WARNING

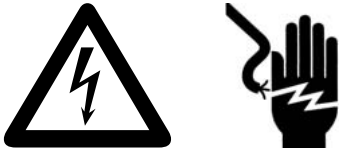

Electrical Shock Hazard

Disconnect electrical power supply cord before performing maintenance on this product.

If product is hard wired into system, disconnect electrical power at the circuit breaker or fuse box before performing maintenance on this product.

Failure to follow these instructions can result in death, fire or electrical shock.

WARNING

Injury Hazard

Product surfaces become very hot during operation, allow product surfaces to cool before handling.

Air stream from product may contain solid or liquid material that can result in eye or skin damage, wear proper eye protection.

Flush this product in a well ventilated area.

Failure to follow these instructions can result in burns, eye injury or other serious injury.

It is your responsibility to:

- Regularly inspect and make necessary repairs to product in order to maintain proper operation.
- Make sure that pressure and vacuum is released from product before starting maintenance.

Check intake and exhaust filters after first 500 hours of operation. Clean filters and determine how frequently filters should be checked during future operation. This one procedure will help to assure the product's performance and service life.

Clean filters when necessary by removing and washing in a solvent or soap and water. In the 32 Series models, filters are inside the pump. After cleaning, dry with compressed air to make sure all moisture is removed before replacing filters.

Flushing

Flushing this product to remove excessive dirt, foreign particles, moisture or oil that occurs in the operating environment will help to maintain proper vane performance.

Use only Gast AH255B Flushing Solvent or other non-petroleum based flushing solvent. Do Not use kerosene or ANY other combustible solvent to flush product.

31 and 33 Series Models

1. Remove the inlet filter.
2. Start the unit up and cover the exhaust port with a cloth (this is to protect you from contact with the solvent).
3. Spray Gast AH255B flushing solvent or any other non-petroleum based solvent directly into inlet port for 5-10 seconds.
4. Plug the inlet port for 20-30 seconds to let the unit pull a vacuum on itself.
5. Release the vacuum and repeat steps 3 and 4 several times or until you hear a change in the sound of the unit. If no change is noticed, a Service Kit may need to be installed. (See Service Kit Installation)

32 and 34 Series Models

1. Remove six end plate bolts. (See exploded view)
2. Use a small hammer to carefully tap on end plate to remove. Use caution when using hammer.
3. Check that vanes are moving freely in and out of vane slots. Replace vanes if more than 50% of the vane extends past the vane slot.
4. Remove vanes and clean both sides with a fine emery cloth. Clean endplate with a fine emery cloth.
5. Flush vanes by spraying with Gast AH255B Flushing Solvent. Remove all solvent from vanes.
6. Flush body, rotor and endplate by spraying with Gast AH255B Flushing Solvent. Remove all solvent from each part.
7. Check body, rotor and end plate for scoring. If each part is clean and shows no signs of scoring, reinstall part. If scoring appears, send unit to factory or replace with new part(s).

Check that all external accessories such as relief valves and gauges are attached to cover and are not damaged before re-operating product.

SHUTDOWN PROCEDURES

It is your responsibility to follow proper shutdown procedures to prevent product damage. NEVER ADD OIL TO THIS OIL-LESS PUMP.

Proper shutdown procedures must be followed to prevent pump damage. Failure to do so may result in premature pump failure. The Gast Manufacturing Rotary Vane Oil-Less Vacuum Pumps and Compressors are constructed of ferrous metals or aluminum which are subject to rust and corrosion when pumping condensable vapors such as water. Follow the steps below to assure correct storage and shutdown between operating periods.

1. Disconnect plumbing.
2. Operate product for at least five minutes without plumbing.
3. Run at maximum vacuum for 10 to 15 minutes.
4. Repeat step 2.
5. Disconnect power supply.
6. Plug open ports to prevent dirt or other contaminants from entering product.

SERVICE KIT INSTALLATION

WARNING



Electrical Shock Hazard

Disconnect electrical power supply cord before installing Service Kit.

If product is hard wired into system, disconnect electrical power at the circuit breaker or fuse box before installing Service Kit.

Vent all air lines to release pressure or vacuum.

Failure to follow these instructions can result in death, fire or electrical shock.

Gast will NOT guarantee field-rebuilt product performance. For performance guarantee, the product must be returned to a Gast Authorized Service Facility.

Service Kit contents vary. Most contain vanes, gaskets and filter parts.

Do Not attempt to remove the rotor. It is held in place by Loctite and can only be serviced by a Gast Authorized Service Facility.

Do Not loosen or adjust motor thru-bolts to prevent misalignment and damage to the pump.

1. Remove the retainer plate screws (3 screws on the 31 and 33 Series and 8 on the 32 and 34 Series).
2. Remove the retainer plate and insert plate located behind the retainer plate by lightly tapping on them with a small hammer. Do Not use a screwdriver to remove these plates to avoid damage to the plates.
3. Before removing the old vanes, check the direction of the bevel edge so the new vanes are installed in the same manner.
4. Spray body bore and rotor with Gast AH255B flushing solvent or any other non-petroleum based flushing solvent.
5. Use a clean dry cloth to remove flushing solvent from parts.
6. Place new vanes in rotor slots in the proper beveled edge direction.
7. Place a sheet of emery cloth on a smooth flat surface and rub both sides of the insert plate located behind the retainer plate to remove any burrs. Use a clean dry cloth to remove any dust from the insert plate. Reinstall the insert plate placing the unused side facing the pump.
8. Repeat step 7 with the face of the metal retainer plate. Use a clean dry cloth to remove any dust from the metal retainer plate and reinstall.
9. Replace the retainer plate screws and tighten to 28 - 36 in. lbs.

Check that all external accessories such as relief valves and gauges are attached to cover and are not damaged before re-operating product.

If pump still does not produce proper vacuum or pressure, send unit to a Gast Authorized Service Facility for repair.

EXPLODED PRODUCT VIEW, PARTS & ORDERING INFORMATION

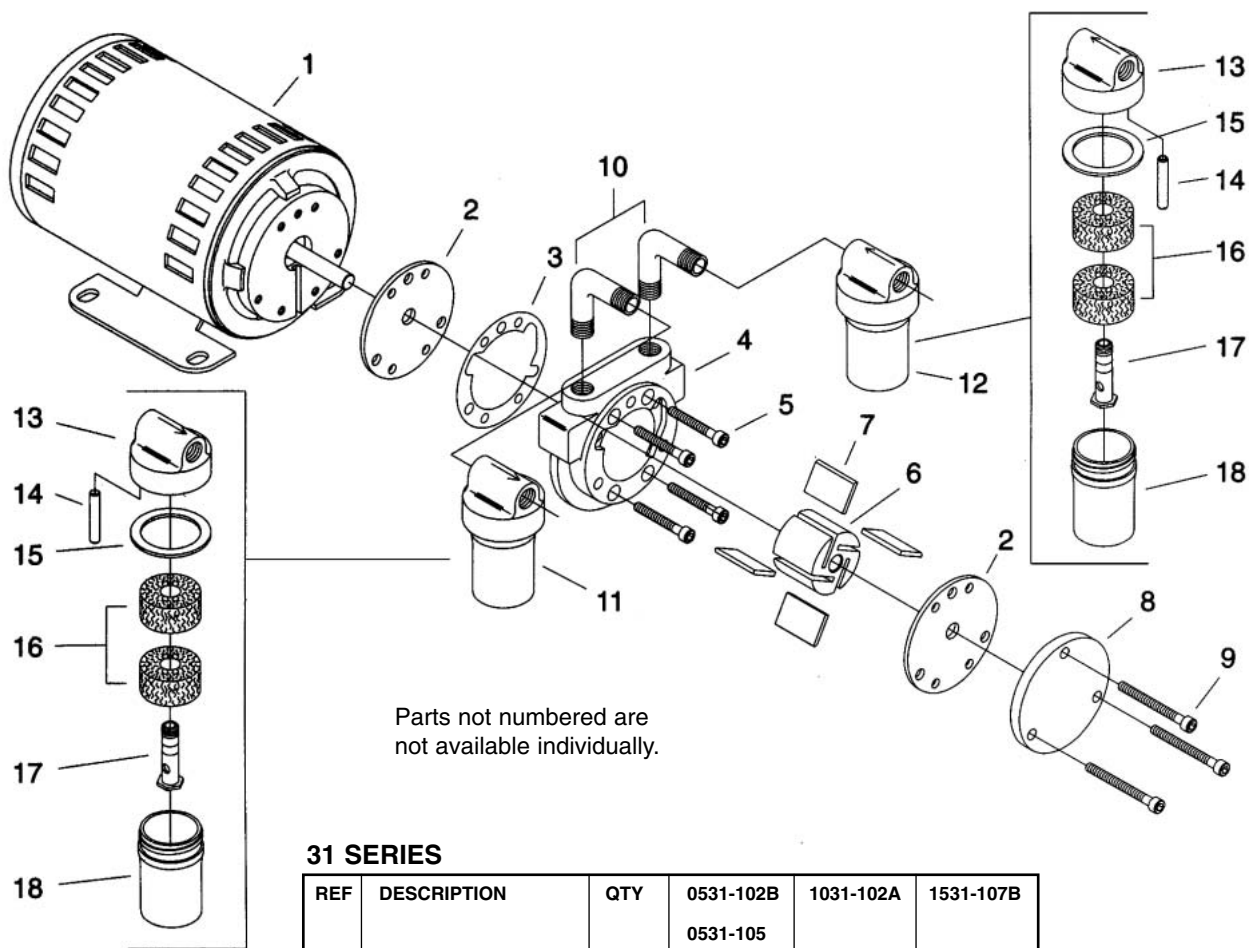

31 SERIES

REF	DESCRIPTION	QTY	0531-102B 0531-105	1031-102A	1531-107B
1	MOTOR	*	*	*	*
2	INSERT PLATE	2	AG293	AG293	AG293
3	GASKET	*	AG296	AG296	AG296
4	BODY	1	AG303	AG302A	AG300
5	BODY BOLT	4	BB425	BB420	BB420
6	ROTOR	1	AF136	AD978	AD978
7 Δ	VANES	4	AF138	AD979	AD979
8	RETAINER PLATE	1	AK791	AK791	AK791
9	RETAINER BOLT	3	BB420	BB423	BB423
10	ELBOW	2	AD987	AD987	AD987
11	MUFFLER	1	AA922H	AA922H	AA922H
12	FILTER	1	AA922H	AA922H	AA922H
13	COVER	2	AA965PCL	AA965PCL	AA965PCL
14	TUB	2	AA739	AA739	AA739
15 Δ	GASKET	2	AA932	AA932	AA932
16 Δ	FELT	4	AA928	AA928	AA928
17	SUPPORT	2	AA927	AA927	AA927
18	GLASS JAR	2	AA935A	AA935A	AA935A
***	SERVICE KIT	1	K259	K219	K219

* Consult the factory.

*** Item not shown.

Δ Denotes parts included in the Service Kit.

Parts listed are for stock models. For specific OEM models, please consult the factory.

When corresponding or ordering parts, please give complete model and serial numbers.

EXPLODED PRODUCT VIEW, PARTS & ORDERING INFORMATION

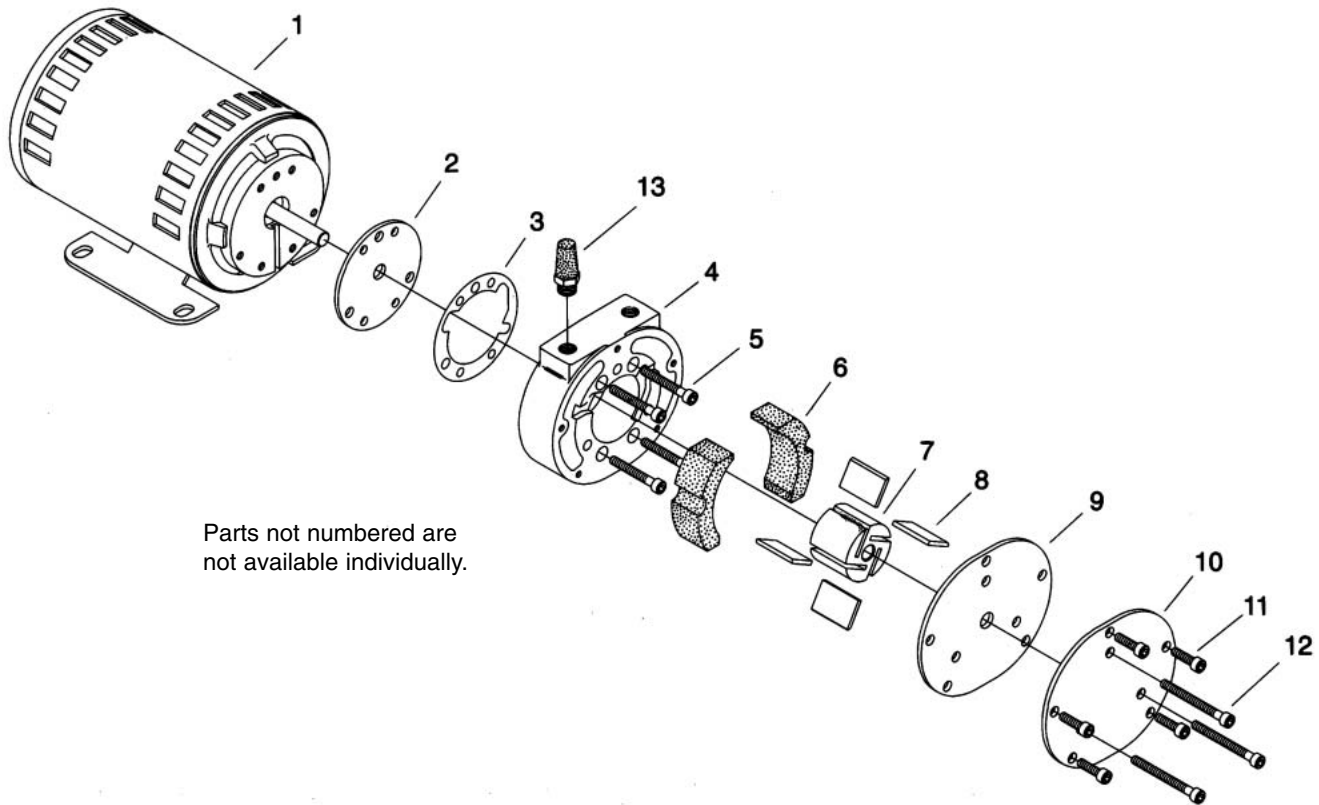

32 SERIES

REF	DESCRIPTION	QTY	0532-101	1032-101	1532-101	2032-101	3032-101
1	MOTOR	*	*	*	*	*	*
2	INSERT PLATE	1	AG293	AG293	AG293	AG293	AJ920
3	GASKET	*	AG296	AG296	AG296	AG296	AJ921
4	BODY	1	AL170	AK649A	AK649B	AL213	AK993A
5	BODY BOLT	4	BB425	BB420	BB420	BB423	BB423
6 Δ	FOAM	2	AK646B	AK646	AK646	AK646A	AK646A
7	ROTOR	1	AF136	AD978	AD978	AJ651	AJ927
8 Δ	VANES	4	AF138	AD979	AD979	AJ652A	AJ958
9	INSERT PLATE	1	AK648	AK648	AK648	AK648	AK995
10	RETAINER PLATE	1	AK647	AK647	AK647	AK647	AK994
11	RETAINER BOLT	5	BB448	BB448	BB448	BB448	BB448
12	RETAINER BOLT	3	BB420	BB423	BB423	BB440	BB440
13	SILENCER	1		VG2016	VG2016	AK840A	AK840A
***	SERVICE KIT	1	K494A	K497	K497	K442A	K554

* Consult the factory.

*** Item not shown.

Δ Denotes parts included in the Service Kit.

Parts listed are for stock models. For specific OEM models, please consult the factory.

When corresponding or ordering parts, please give complete model and serial numbers.

EXPLODED PRODUCT VIEW, PARTS & ORDERING INFORMATION

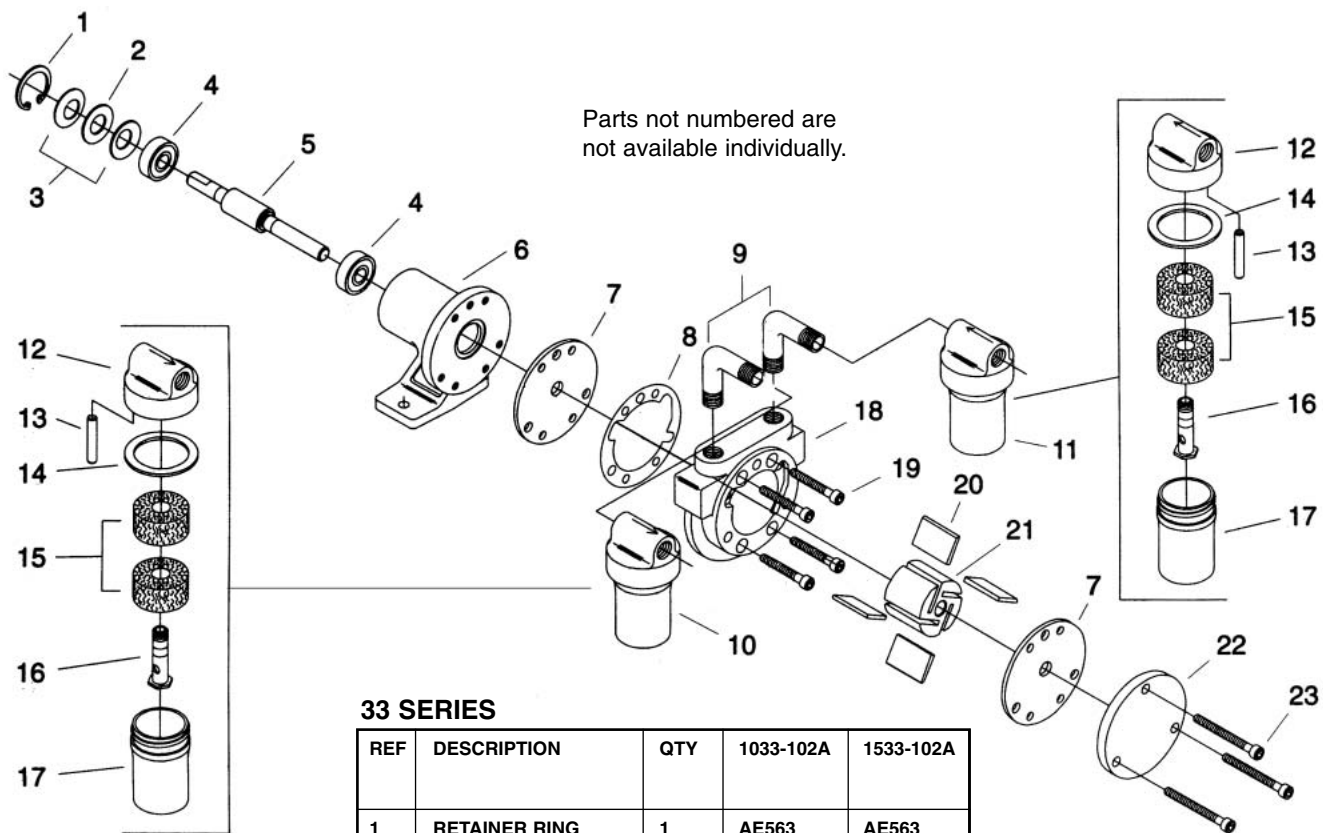

33 SERIES

REF	DESCRIPTION	QTY	1033-102A	1533-102A
1	RETAINER RING	1	AE563	AE563
2	BELLEVILLE SPRING	4	AE664A	AE664A
3	SHIM WASHER	2	AE686-1	AE686-1
4	BEARING	2	AF120	AF120
5	SHAFT	1	AD234	AD234
6	END PLATE	1	AG315	AG315
7	INSERT PLATE	2	AG293	AG293
8	GASKET	1	AG296	AG296
9	ELBOWS	2	AD987	AD987
10	MUFFLER	1	AA922H	AA922H
11	FILTER	1	AA922H	AA922H
12	COVER	2	AA965PCL	AA965PCL
13	TUBE	2	AA739	AA739
14 Δ	GASKET	2	AA932	AA932
15 Δ	FELT	4	AA928	AA928
16	SUPPORT TUBE	2	AA927	AA927
17	GLASS JAR	2	AA935A	AA935A
18	BODY	1	AG302A	AG300B
19	BODY BOLT	4	BB426	BB426
20 Δ	VANES	4	AD979	AD979
21	ROTOR	1	AD978	AD978
22	RETAINER PLATE	1	AK791	AK791
23	PLATE SCREWS	3	BB423	BB423
***	SERVICE KIT	1	K219	K219

*** Item not shown.

Δ Denotes parts included in the Service Kit.

Parts listed are for stock models. For specific OEM models, please consult the factory.

When corresponding or ordering parts, please give complete model and serial numbers.

EXPLODED PRODUCT VIEW, PARTS & ORDERING INFORMATION

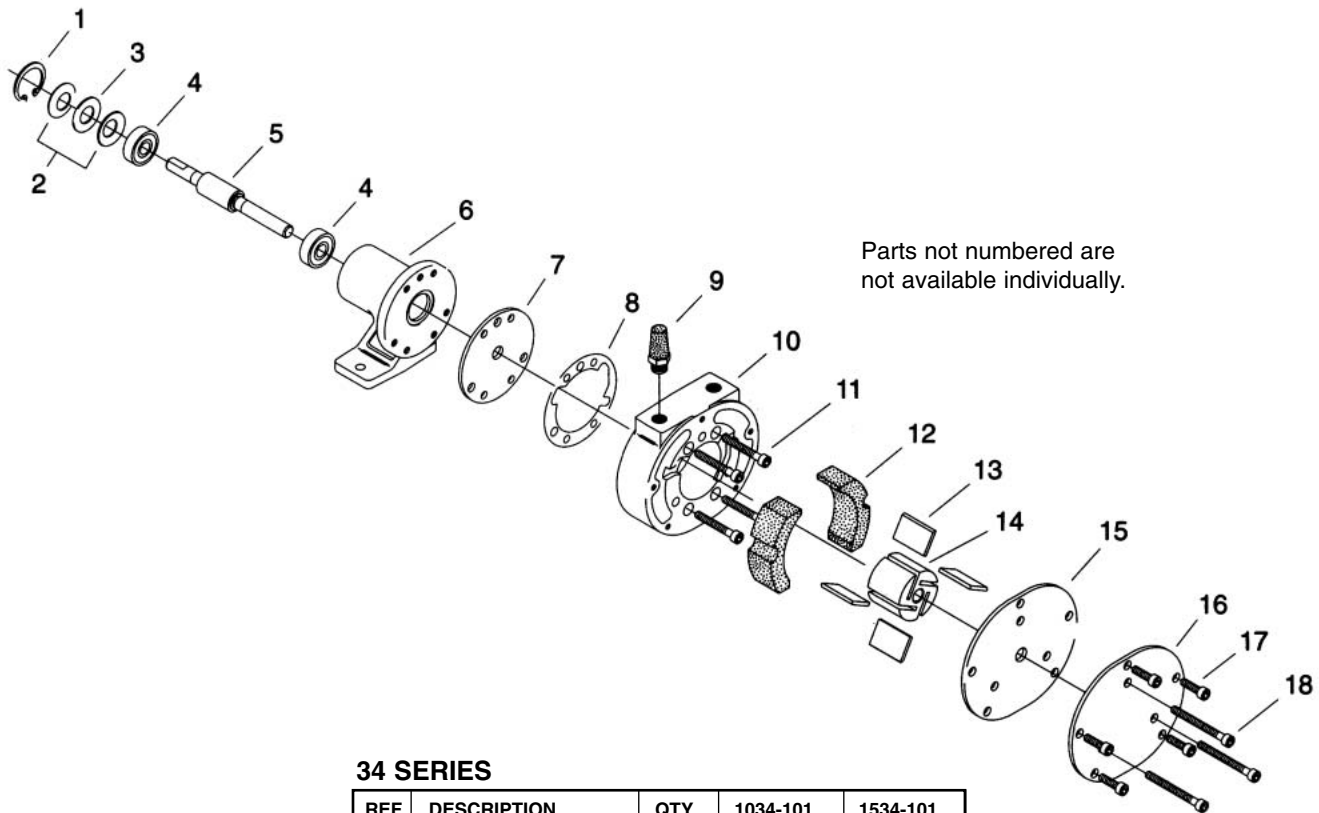

34 SERIES

REF	DESCRIPTION	QTY	1034-101	1534-101
1	RETAINER RING	1	AE563	AE563
2	BELLEVILLE SPRING	4	AE664A	AE664A
3	SHIM WASHER	2	AE686-1	AE686-1
4	BEARING	2	AF120	AF120
5	SHAFT	1	AD234	AD234
6	END PLATE	1	AG315	AG315
7	INSERT PLATE	2	AG293	AG293
8	GASKET	1	AF296	AF296
9	SILENCER	1	VG2016	VG2016
10	BODY	1	AK649A	AK649B
11	BODY BOLT	4	BB426	BB426
12 Δ	FOAM	2	AK646	AK646
13 Δ	VANES	4	AD979	AD979
14	ROTOR	1	AD978	AD978
15	INSERT PLATE	1	AK648	AK648
16	RETAINER PLATE	1	AK647	AK647
17	PLATE BOLTS	5	BB448	BB448
18	PLATE BOLTS	3	BB427	BB427
***	SERVICE KIT	1	K497	K497

*** Item not shown.

Δ Denotes parts included in the Service Kit.

Parts listed are for stock models. For specific OEM models, please consult the factory.

When corresponding or ordering parts, please give complete model and serial numbers.

WIRING INSTRUCTIONS & INFORMATION

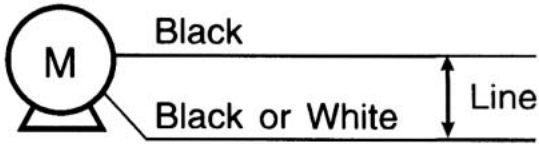

< MOTOR WITH INTERNAL CAPACITOR

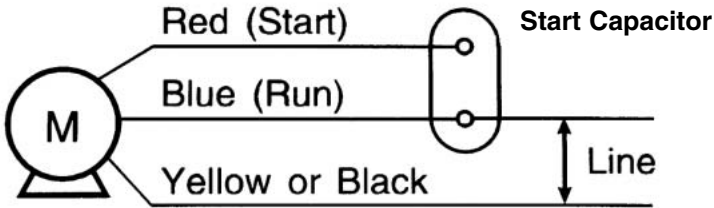

< MOTOR WITH 3 LEADS & CAPACITOR

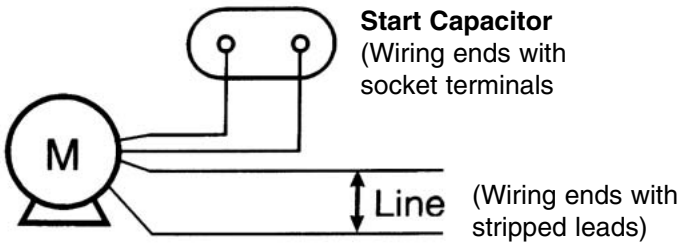

< MOTOR WITH 4 LEADS

AL338 (115V) & AL339 (230V) STEARNS SWITCH ASSEMBLY

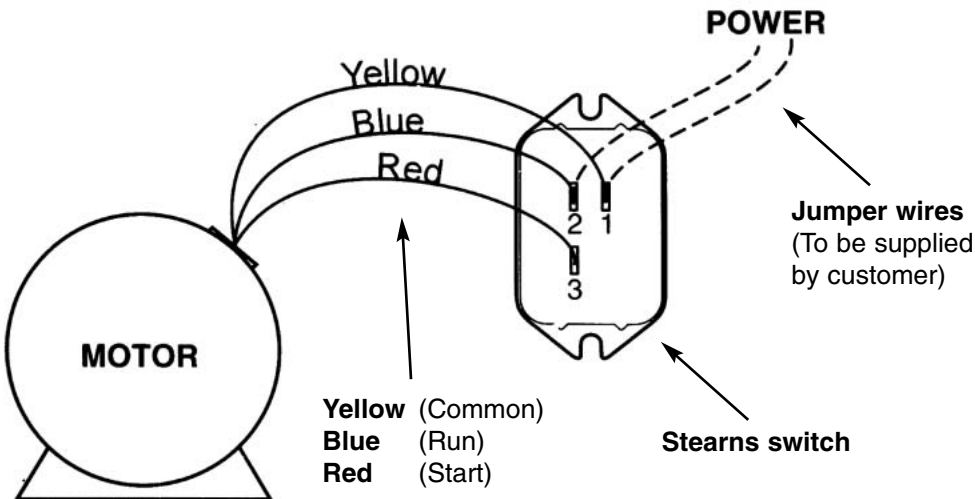

The Stearns switch assembly replaces the start relay on motors that require one. **Do Not attempt to wire a Stearns switch as you would a relay as this will damage the switch. Wire switch according to diagram shown.**

If motor fails to start or overheats after installation of this switch, disconnect power and review instructions or contact a Gast Authorized Service Facility.

PART NO. 70 - 205 G335PL (REV-E)

TROUBLESHOOTING CHART

Low		High		Pump Overheat	Motor Overload	Reason and remedy for problem.
Vacuum	Pressure	Vacuum	Pressure			
●	●	At pump		●	●	Filter dirty. Clean or replace.
	●		At pump	●	●	Muffler dirty. Clean or replace.
●		At pump		●	●	Vacuum line collapsed. Repair or replace.
			●	●	●	Relief valve set too high. Inspect and adjust.
●	●					Relief valve set too low. Inspect and adjust.
●	●	At pump	At pump	●	●	Plugged vacuum/pressure line. Inspect and repair.
●	●					Vanes sticking. Clean or replace.
●	●					Vanes worn. Replace.
●	●					Shaft seal worn. Replace.
●	●			●	●	Dust or offset powder in pump. Inspect and clean.
●	●			●	●	Motor not wired correctly. Check wiring diagram and line voltage.

AUTHORIZED SERVICE FACILITIES

Gast Manufacturing Inc.
2550 Meadowbrook Road
Benton Harbor, MI 49022
TEL: 616-926-6171
FAX: 616-927-0808
www.gastmfg.com

Gast Manufacturing Inc.
505 Washington Ave
Carlstadt, NJ 07072
TEL: 201-933-8484
FAX: 201-933-5545

Brenner Fiedler & Assoc.
13824 Bentley Place
Cerritos, CA 90701
TEL: 800-843-5558
TEL: 310-404-2721
FAX: 310-404-7975

Gast Manufacturing Co., Ltd
Beech House, Knaves Beech
Business Centre, Loudwater
High Wycombe, Bucks HP 10 9SD
England
TEL: 44 628 532600
FAX: 44 628 532470

Wainbee Limited
215 Brunswick Blvd.
Pointe Claire, Quebec
Canada H9R 4R7
TEL: 514-697-8810
FAX: 514-697-3070

Wainbee Limited
5789 Coopers Avenue
Mississauga, Ontario
Canada L4Z 3S6
TEL: 905-568-1700
FAX: 905-568-0083

Japan Machinery Co., Ltd.
Central PO Box 1451
Tokyo, 100-91 Japan
TEL: 81-3-3573-5421
FAX: 81-3-3571-7865
or: 81-3-3571-7896

General Correspondence
should be sent to:
Gast Mfg. Inc./A Unit of IDEX Corporation
P O Box 97
Benton Harbor, MI 49023-0097



A Unit of IDEX Corporation

ISO 9001 & 14001 CERTIFIED

www.gastmfg.com