

Sequence valves control the order of events within a hydraulic system by directing pressure to the two circuits in a pressure-controlled sequence. For example, this allows clamps to be actuated before work supports are locked.

Initially, the valve is closed. Oil flows to the primary circuit until pressure reaches the valve setting. The valve then opens to deliver oil to the secondary circuit while holding pressure on the primary circuit. Once secondary and primary pressures are equal, the pressure increases uniformly in both circuits. There is no reduction of pressure available to either circuit.

Features:

- Sequence pressure range is adjustable from 0 to 4,000 psi
- Usable with hydraulic systems operating up to 5,000 psi
- Will not reduce pressure to the secondary circuit
- Minimum operation pressure should be 120% of sequence pressure setting
- Internal check valve allows free flow in reverse direction
- Maximum flow rate 5 gpm
- Suitable for single- and double-acting circuits
- NPT, SAE or manifold mounting

Pressure Sequence Valves

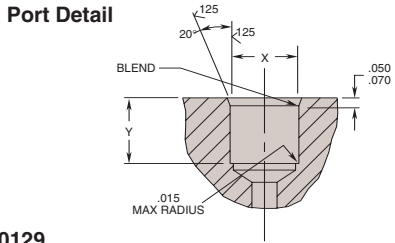
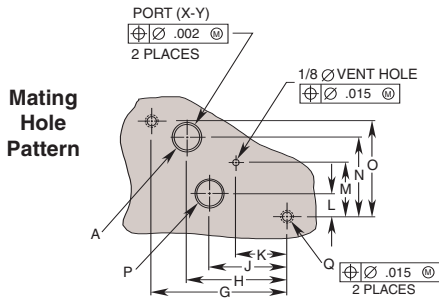

100129

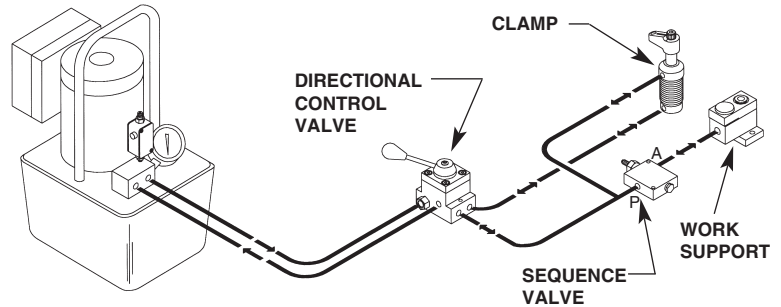
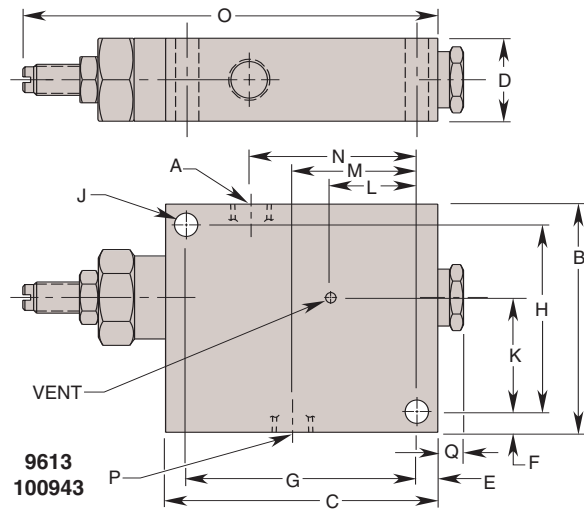
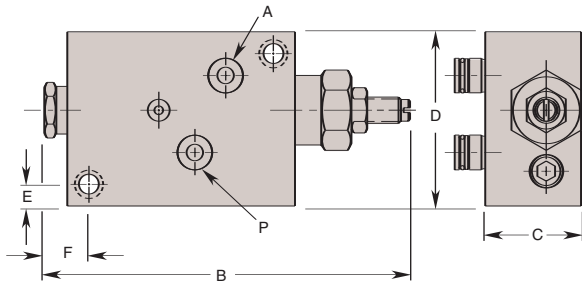

Cat. No.	Dimensions (In Inches)																	
	A	B	C	D	E	F	G	H	J	K	L	M	N	O	P	Q	X Dia.	Y
100129	*	5.250	1.375	2.500	.312	.625	2.645	1.960	1.520	1.000	.456	1.063	1.560	1.875	*	1/4-20 UNC	.500 .503	.515 .535

NOTE: *See Port Detail drawing for Ports A and P.

Cat. No.	Dimensions (In Inches)																
	"A" Port	B	C	D	E	F	G	H	J Dia.	K	L	M	N	O	"P" Port	Q	
9613	1/4 NPTF	2.750	3.281	1.000	.250	.250	2.781	2.250	.281	1.375	1.040	1.500	2.000	5.000	1/4 NPTF	.312	
100943	7/16-20UNF SAE-4														7/16-20UNF SAE-4		