

5150 SERIES

Heavy-Duty Straight Line Action Clamps | Product Overview

Features:

- Square plunger provides positive radial location
- Reverse action allows the handle to stay out of the work zone
- Hardened steel pivot pins and bushings provide long life
- Black oxide finish with hardened plungers

Applications:

- Welding fixtures
- Assembly fixtures
- Light machining

5150/5150-M
Flanged Base



5150-B/5150-MB
Solid Base



5150-R/5150-MR
Flanged Base with DESTACO® Toggle Lock Plus™



5150-BR①/5150-MBR①
Solid Base with DESTACO® Toggle Lock Plus™



Technical Information

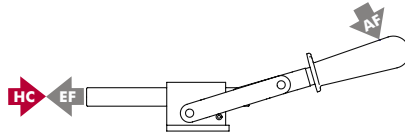

Model	Max. Holding Capacity	Weight	EF:AF (pushing)	Plunger Travel mm [in]	Handle Opening	Plunger Thread (M)	Recommended Spindle (not supplied)
5150	[5800 lbf] 25800 N	[3.00lbs] 1,36 kg	40:1	[1.91] 48,4	125°	1/2-13	325203
5150-M						M12	220203-M
5150-B		[2.50lbs] 1,13 kg				1/2-13	325203
5150-MB						M12	220203-M
5150-R		[3.15lbs] 1,43 kg				1/2-13	325203
5150-MR						M12	220203-M
5150-BR①		[2.68lbs] 1,22 kg				1/2-13	325203
5150-MBR①						M12	220203-M

① This item is available upon request **HC** = Holding Capacity, **EF** = Exerting Force, **AF** = Applied Force

5150 SERIES

Heavy-Duty Straight Line Action Clamps | Product Overview

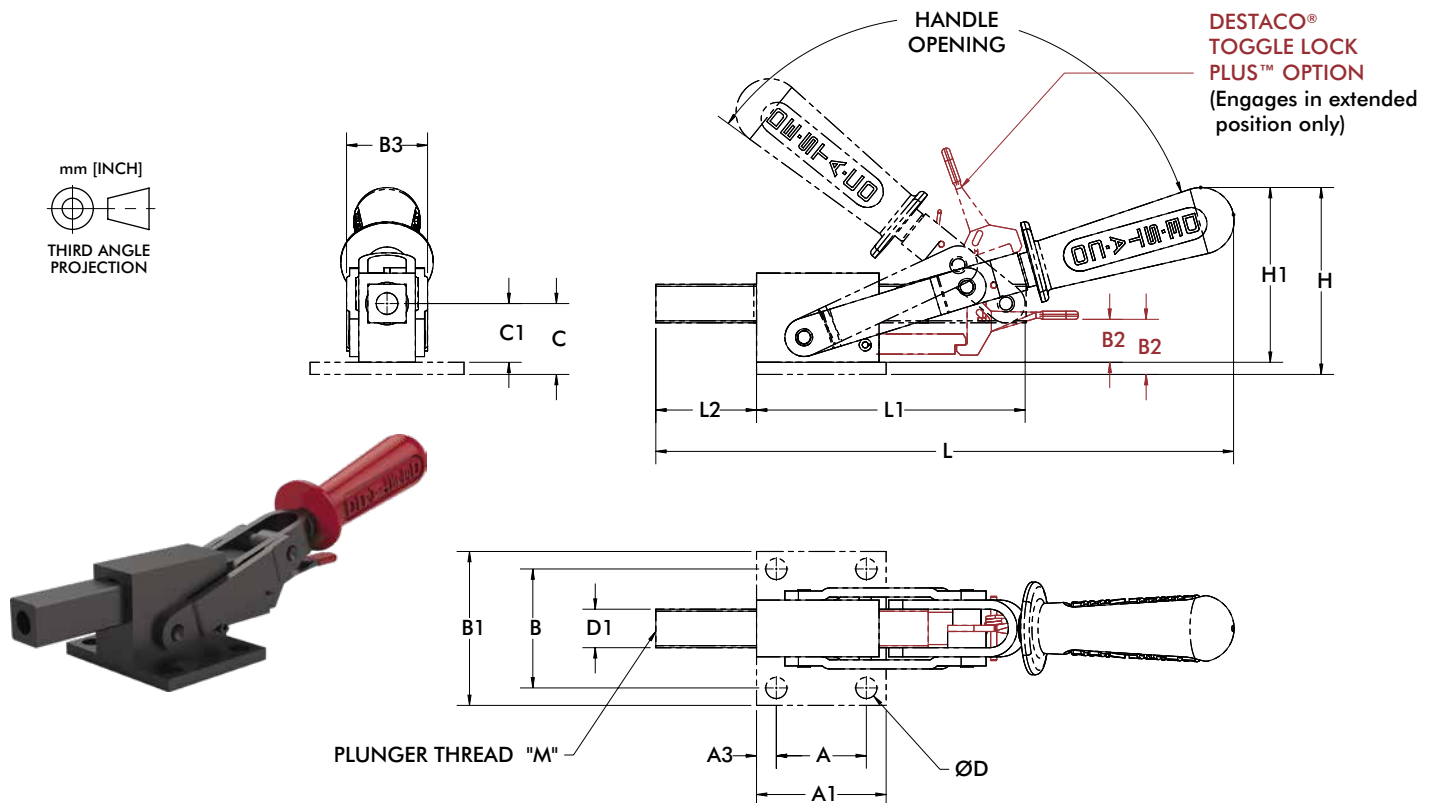

Model	A	A1	A3	B	B1	B2	B3	C	C1	D	D1
5150	[1.75]	[2.52]	[0.38]	[2.31]	[2.99]			[1.57]	-	[0.41]	
5150-M	44,5	64	9,8	58,7	76			35	-	10,5	
5150-B	-	-	-	-	-				[1.14]	-	
5150-MB	-	-	-	-	-		[1.57]		29	-	[0.75]
5150-R	[1.75]	[2.52]	[0.38]	[2.31]	[2.99]	[1.07]	40	[1.57]	-	[0.41]	19
5150-MR	44,5	64	9,8	58,7	76	27,2		35	-	10,5	
5150-BR	-	-	-	-	-	[0.84]			[1.14]	-	
5150-MBR	-	-	-	-	-	21,2			29	-	

Model	H	H1	L	L1	L2	M
5150	[3.63]	-				1/2-13
5150-M	92,3	-				M12
5150-B	-	[3.40]				1/2-13
5150-MB	-	86,3	[11.23]	[2.86]	[1.96]	M12
5150-R	[3.63]	-	285,3	72,6	49,7	1/2-13
5150-MR	92,3	-				M12
5150-BR ⓘ	-	[3.40]				1/2-13
5150-MBR ⓘ	-	86,3				M12

ⓘ This item is available upon request