

Use this number when searching for this item:

9030960158700

5/8" RF 50 CARBIDE end mill FIREX

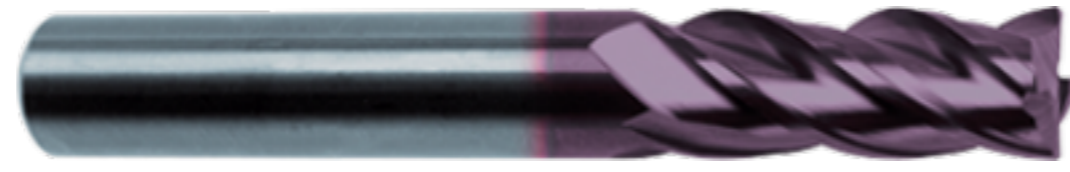

>> Item Info

EDP #	9030960158700
Series	3096
Order Code	15.870
Coating	FIREX
Coolant	Without
Cutting Direction	Right Hand
Cutting Edge	Corner Chamfer
Helix Angle	40
Material	Carbide
Shank	HA / HB
Type	RF 50
Tolerance	h10

>> Features

>> Suggested Materials

P	• Steel
M	Stainless steel
K	• Grey cast iron, malleable and spheroidal iron
N	Aluminium and other non-ferrous metal
S	Special, super and titanium alloys
H	Hardened steel and chilled cast iron

• = optimal, o = secondary

>> Technical Specs

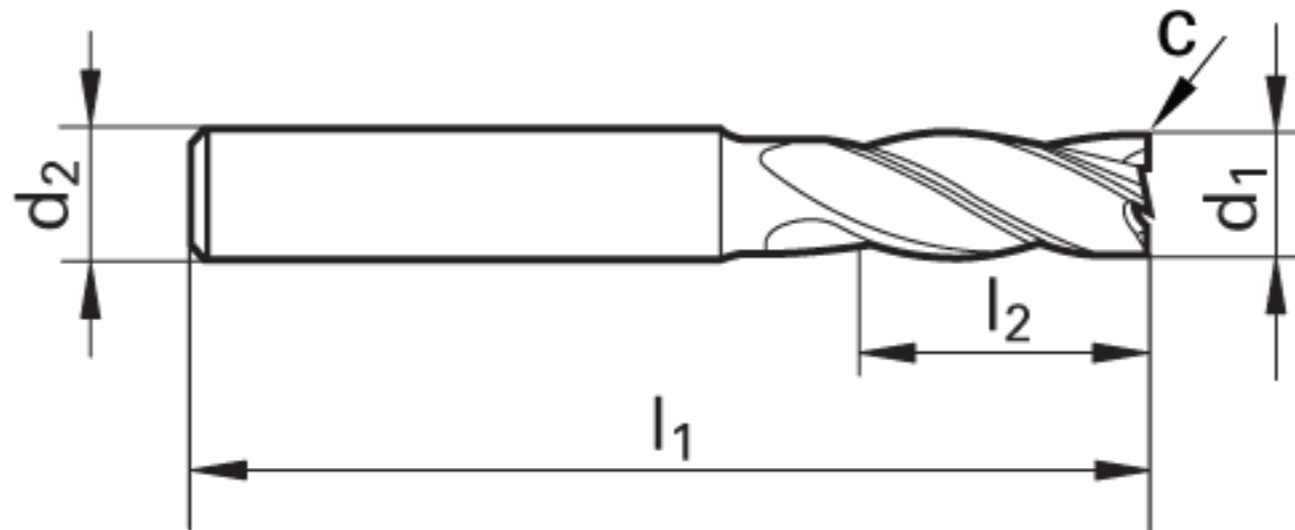

EDP #	Code No.	Dia. d1 (in)	Shank dia. d2 h6 (in)	Neck dia. d3 (in)	OAL l1 (in)	LOC l2 (in)	Reach l3 (in)			Corner Radius (in)	Corner Chamfer (in)	β °	Flutes	Shank Type
9030960158700	15.870	5/8	5/8		3 1/2	1 1/4					0.014		4	HB Weldon flat



WARNING:
This product can expose you to cobalt metal powder, a chemical known to the State of California to cause cancer. For more information go to www.P65Warnings.ca.gov

*** **DISCLAIMER:** Data on this PDF is subject to change at any time without notice.