

Use this number when searching for this item:

9030930031700

1/8" Uni-Pro CARBIDE end mill FIREX



>> Item Info

EDP #	9030930031700
Series	3093
Order Code	3.170
Coating	FIREX
Coolant	Without
Cutting Direction	Right Hand
Cutting Edge	Corner Chamfer
Helix Angle	30
Material	Carbide
Shank	HA Cylindrical
Type	Uni-Pro
Tolerance	h10

>> Features

>> Suggested Materials

P	• Steel
M	• Stainless steel
K	• Grey cast iron, malleable and spheroidal iron
N	Aluminium and other non-ferrous metal
S	Special, super and titanium alloys
H	Hardened steel and chilled cast iron

• = optimal, o = secondary

>> Technical Specs

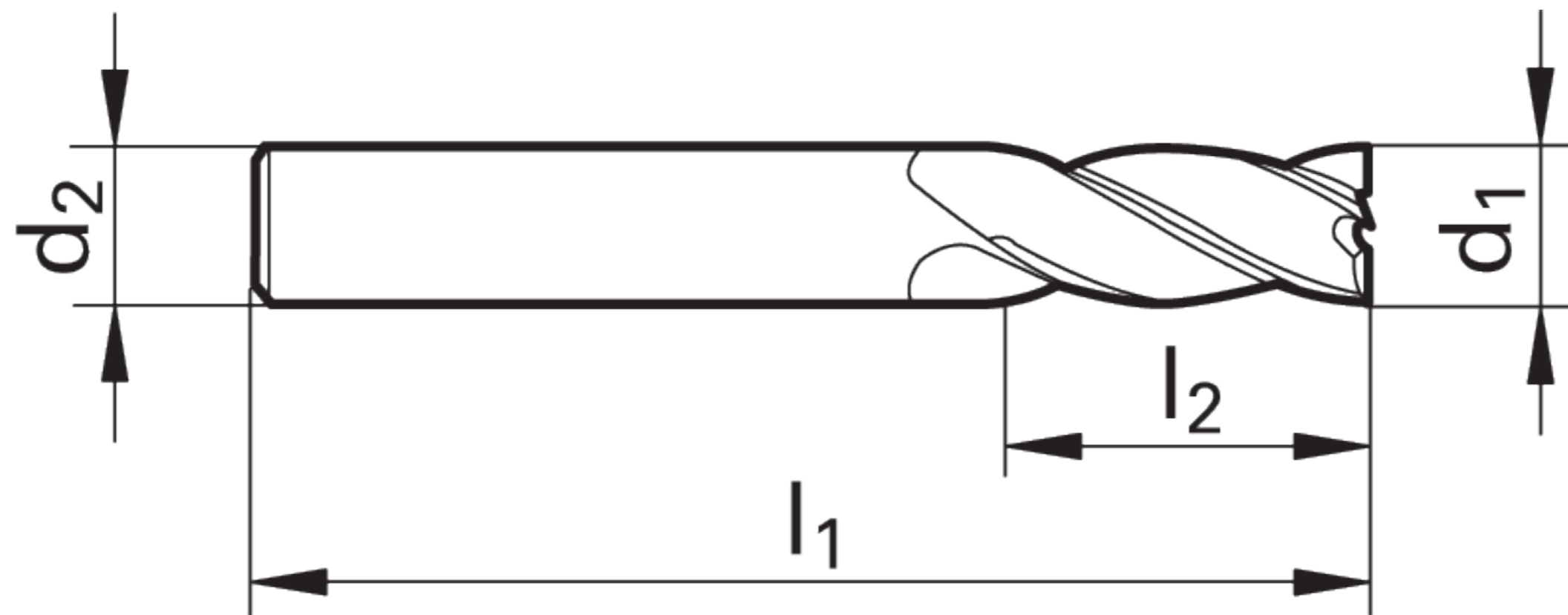

EDP #	Code No.	Dia. d1 (in)	Shank dia. d2 h6 (in)	Neck dia. d3 (in)	OAL l1 (in)	LOC l2 (in)	Reach l3 (in)			Corner Radius (in)	Corner Chamfer (in)	β °	Flutes	Shank Type
903093003 1700	3.170	1/8	1/8		2	1/4					0.002		4	HA cylindrical



WARNING:
This product can expose you to cobalt metal powder, a chemical known to the State of California to cause cancer. For more information go to www.P65Warnings.ca.gov

*** **DISCLAIMER:** Data on this PDF is subject to change at any time without notice.