

Use this number when searching for this item:

## 9030890095220

### 3/8" Uni-Pro CARBIDE end mill 0.015R FIREX



#### >> Item Info

EDP #	9030890095220
Series	3089
Order Code	9.522
Coating	FIREX
Coolant	Without
Cutting Direction	Right Hand
Cutting Edge	Corner Radius
Helix Angle	30
Material	Carbide
Shank	HA Cylindrical
Type	Uni-Pro
Tolerance	h10

#### >> Features

#### >> Suggested Materials

<b>P</b>	• Steel
<b>M</b>	• Stainless steel
<b>K</b>	• Grey cast iron, malleable and spheroidal iron
<b>N</b>	Aluminium and other non-ferrous metal
<b>S</b>	Special, super and titanium alloys
<b>H</b>	Hardened steel and chilled cast iron

• = optimal, o = secondary

#### >> Technical Specs

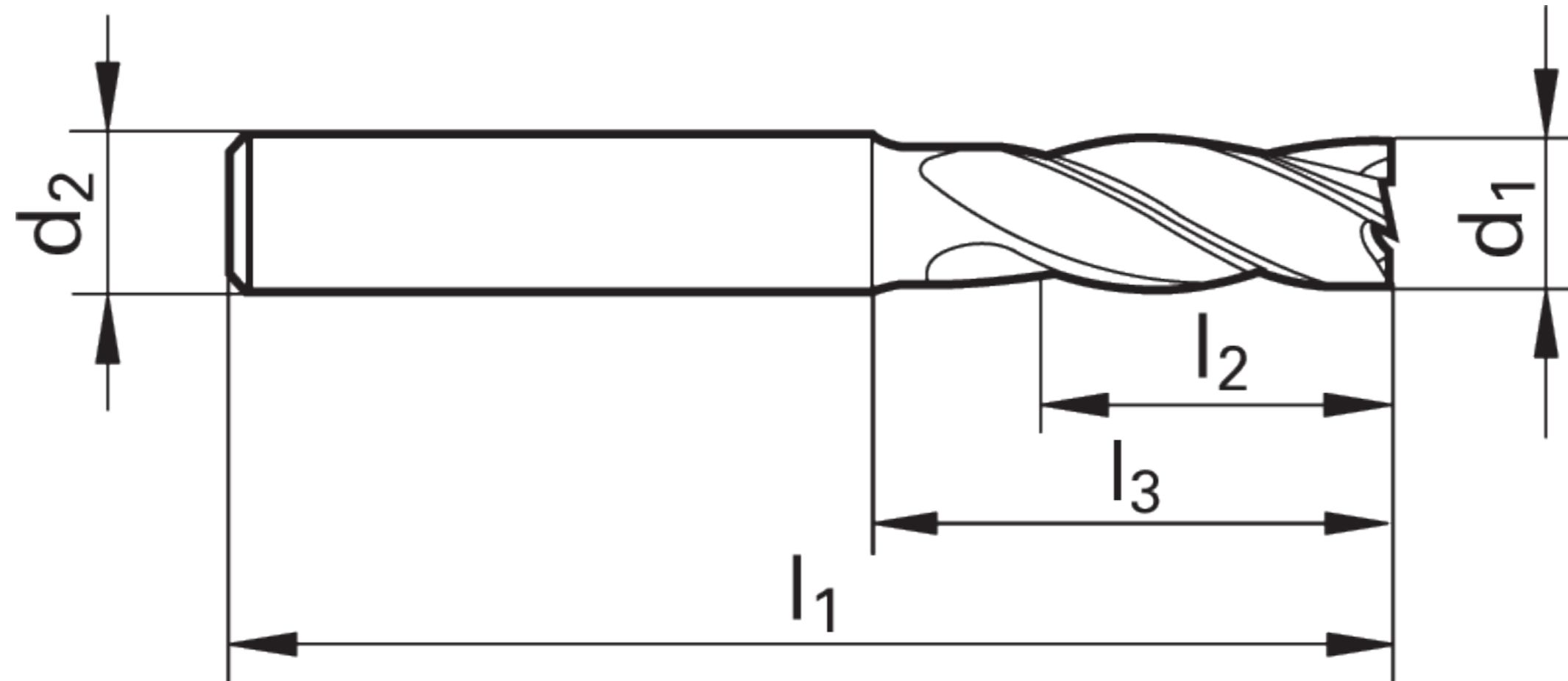

EDP #	Code No.	Dia.	Shank dia.	Neck dia.	OAL	LOC	Reach			Corner	Corner		Flutes	Shank Type
		d1	d2 h6	d3	l1	l2	l3	l4	l5	Radius	Chamfer	β		
		(in)	(in)	(in)	(in)	(in)	(in)	(in)	(in)	(in)	(in)	°		
9030890095220	9.522	3/8	3/8		2 1/2	1				0.015			4	HA cylindrical



**WARNING:**  
This product can expose you to cobalt metal powder, a chemical known to the State of California to cause cancer. For more information go to [www.P65Warnings.ca.gov](http://www.P65Warnings.ca.gov)

\*\*\* **DISCLAIMER:** Data on this PDF is subject to change at any time without notice.