

Use this number when searching for this item:

9030890079420

5/16" Uni-Pro CARBIDE end mill 0.015R FIREX



>> Item Info

EDP #	9030890079420
Series	3089
Order Code	7.942
Coating	FIREX
Coolant	Without
Cutting Direction	Right Hand
Cutting Edge	Corner Radius
Helix Angle	30
Material	Carbide
Shank	HA Cylindrical
Type	Uni-Pro
Tolerance	h10

>> Features

>> Suggested Materials

P	• Steel
M	• Stainless steel
K	• Grey cast iron, malleable and spheroidal iron
N	Aluminium and other non-ferrous metal
S	Special, super and titanium alloys
H	Hardened steel and chilled cast iron

• = optimal, o = secondary

>> Technical Specs

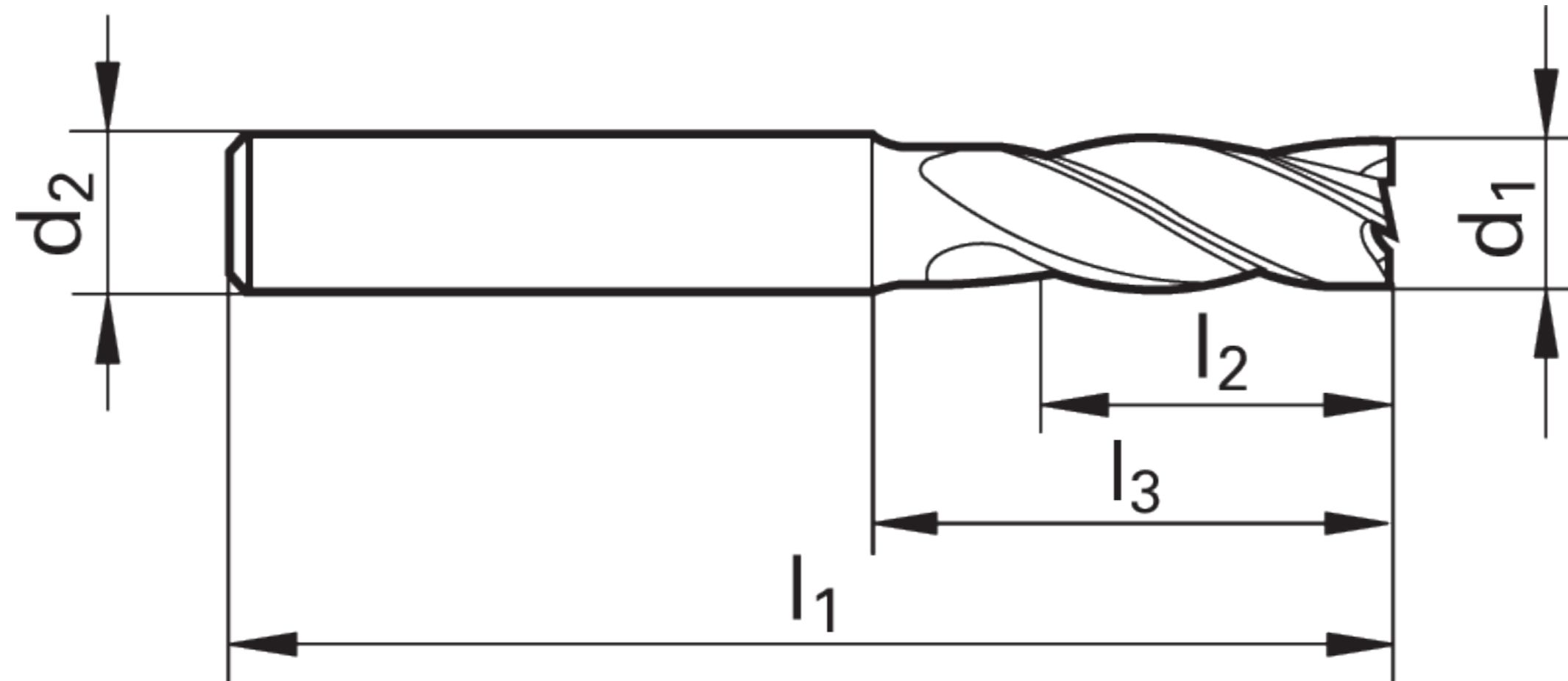

EDP #	Code No.	Dia.	Shank dia.	Neck dia.	OAL	LOC	Reach			Corner	Corner		Flutes	Shank Type
		d1	d2 h6	d3	l1	l2	l3	l4	l5	Radius	Chamfer	β		
		(in)	(in)	(in)	(in)	(in)	(in)	(in)	(in)	(in)	(in)	°		
9030890079420	7.942	5/16	5/16		2 1/2	13/16				0.015			4	HA cylindrical



WARNING:
This product can expose you to cobalt metal powder, a chemical known to the State of California to cause cancer. For more information go to www.P65Warnings.ca.gov

*** **DISCLAIMER:** Data on this PDF is subject to change at any time without notice.