

Use this number when searching for this item:

## 9030230120000

### 12MM Uni-Pro Carbide end mill FIREX



#### >> Item Info

EDP #	9030230120000
Series	3023
Order Code	12.000
Coating	FIREX
Coolant	Without
Cutting Direction	Right Hand
Cutting Edge	Corner Chamfer
Helix Angle	30
Material	Carbide
Shank	HA Cylindrical
Type	Uni-Pro
Tolerance	h10

#### >> Features

- centre cutting

#### >> Suggested Materials

<b>P</b>	• Steel
<b>M</b>	• Stainless steel
<b>K</b>	• Grey cast iron, malleable and spheroidal iron
<b>N</b>	Aluminium and other non-ferrous metal
<b>S</b>	Special, super and titanium alloys
<b>H</b>	Hardened steel and chilled cast iron

• = optimal, o = secondary

#### >> Technical Specs

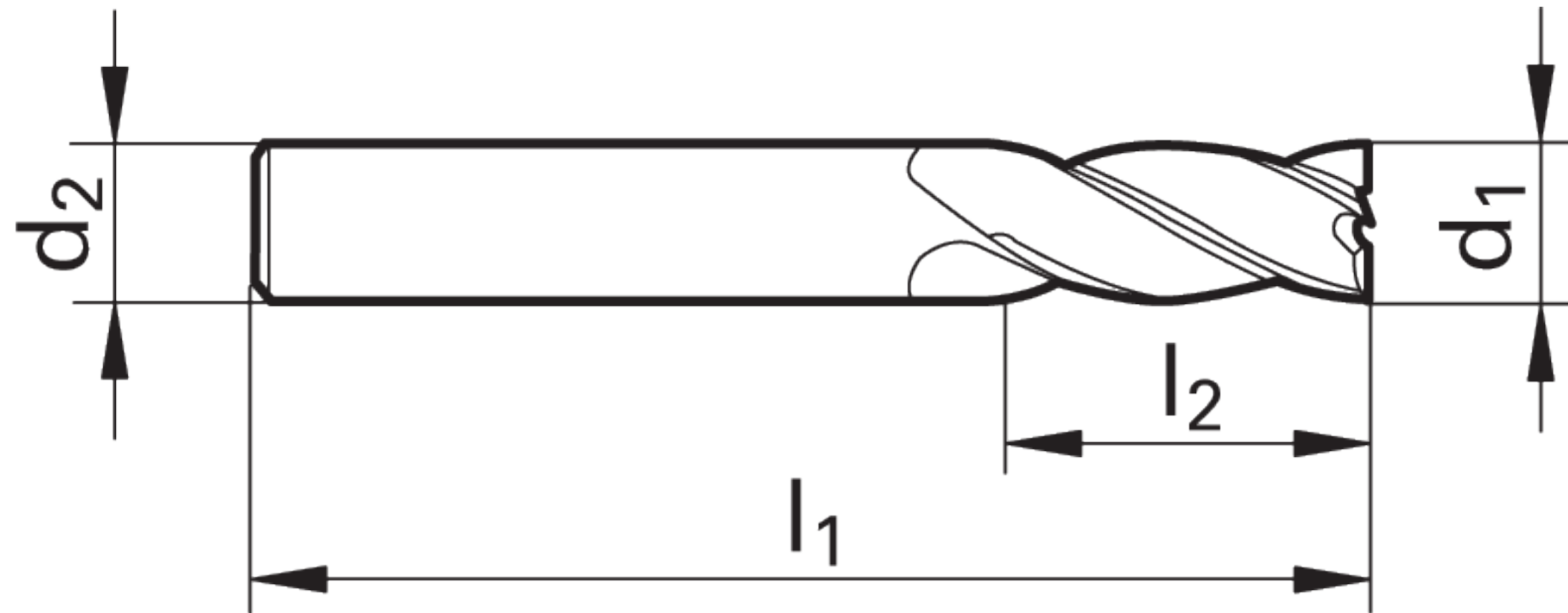

EDP #	Code No.	Dia d1 (mm)	Shank dia d2 h6 (mm)	Neck dia. d3 (mm)	OAL l1 (mm)	LOC l2 (mm)	Reach l3 (mm)			Corner Radius (mm)	Corner Chamfer (mm)	β °	Flutes	Shank Type	Coating
9030230120000	12.000	12.00	12.00		150.00	45.00					0.15		4	HA cylindrical	FIREX



**WARNING:**  
This product can expose you to cobalt metal powder, a chemical known to the State of California to cause cancer. For more information go to [www.P65Warnings.ca.gov](http://www.P65Warnings.ca.gov)

\*\*\* **DISCLAIMER:** Data on this PDF is subject to change at any time without notice.