

2002 SERIES

Vertical Hold Down Clamps | Product Overview

Features:

- Large hand clearance for improved safety
- Bolt pattern interchangeable with 202 Series
- Three times the holding capacity of 202 Series
- Hardened bushings at key pivot points
- Near vertical clamping contact
- BLK models feature a black, non-reflective finish
- 5 handle colors - see page MC-PRO-7 for details

Applications:

- Checking fixtures
- Assembly & test
- Light machining
- Woodworking

Also Available:

See page MC-ACC-1 for accessories
Accepts M6 or 1/4 spindle accessories

Covered under one or more U.S./International Patents

2002-U/USS
Flanged Base
U-Bar



-USS Stainless Steel Model



2002-U-LS-BLK ⓘ
Blackout Series
Flanged Base
U-Bar



2002-S
Flanged Base
Solid Bar



2002-UB
Straight Base
U-Bar



2002-UB-LS-BLK ⓘ
Blackout Series
Straight Base
U-Bar



2002-SB
Straight Base
Solid Bar



2002-UR/URSS
Flanged Base
U-Bar
DESTACO®
Toggle Lock Plus



-URSS Stainless Steel Model



2002-SR ⓘ
Flanged Base
Solid Bar
DESTACO®
Toggle Lock Plus



2002-UBR
Straight Base
U-Bar
DESTACO®
Toggle Lock Plus



2002-SBR ⓘ
Straight Base
Solid Bar
DESTACO®
Toggle Lock Plus



2002-U207
Flanged Base
U-Bar

Interchangeable
with 207 Series



2002-UR207
Flanged Base
U-Bar

Interchangeable
with 207 Series
DESTACO®
Toggle Lock Plus



2002-UF
Front Mount Base
U-Bar



Color Handles

Available on models
in this series that use
standard red handles.*
Add -Y, -G, -B, -K to
end of model number.

*Excludes Blackout Series,
Toggle Lock Plus levers
or dipped handles.



ⓘ This item is available upon request

2002 SERIES

Vertical Hold Down Clamps | Technical Information

Model	Max. Holding Capacity	Clamp Bar Opening(+10°)	Handle Opening (+10°)	Weight	Accessories (Supplied)				
					Bolt Retainer	Spindle Assembly	Flanged Washers		
2002-U	[600 lbf] 2700 N	75°	66°	[0.48 lbs] 0,22 kg	--	215208-M	215105		
2002-USS					--	202943-M	215905		
2002-U-LS-BLK ⓘ					--	--	215105-BLK		
2002-S					2002115-E	--	--		
2002-UB					--	215208-M	215105		
2002-UB-LS-BLK ⓘ					--	--	215105-BLK		
2002-SB				2002115-E	--	--			
2002-UR				--	215208-M	215105			
2002-URSS				--	202943-M	215905			
2002-SR ⓘ				2002115-E	--	--			
2002-UBR				--	215208-M	215105			
2002-SBR ⓘ				2002115-E	--	--			
2002-U207				90°	72°	[0.57 lbs] 0,26 kg	--	215208-M	215105
2002-UR207				75°	57°	[0.66 lbs] 0,30 kg	--	215208-M	215105
2002-UF	75°	66°	[0.66 lbs] 0,30 kg	--	215208-M	215105			

ⓘ This item is available upon request

Holding Capacities

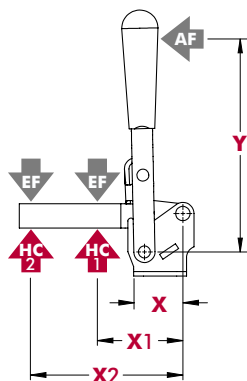

Model	X	X1	X2	Y	±HC1	±HC2	±EF(X1):AF	±EF(X2):AF
2002-()	[1.12] 28,5	[1.45] 37	[2.64] 67	[3.66] 93	[600 lbf] 2700 N	[295 lbf] 1310 N	11:1	5:1

Dimensions shown "mm [inch]" ± HC = Holding Capacity, EF = Exerting Force, AF = Applied Force
See page MC-TEC-4 for additional information.

2002 SERIES

Vertical Hold Down Clamps | Dimensions | -U/-USS/-S/-UB/-SB/-UR/-URSS/-SR/-UBR/-SBR

2002-U Flanged Base U-Bar

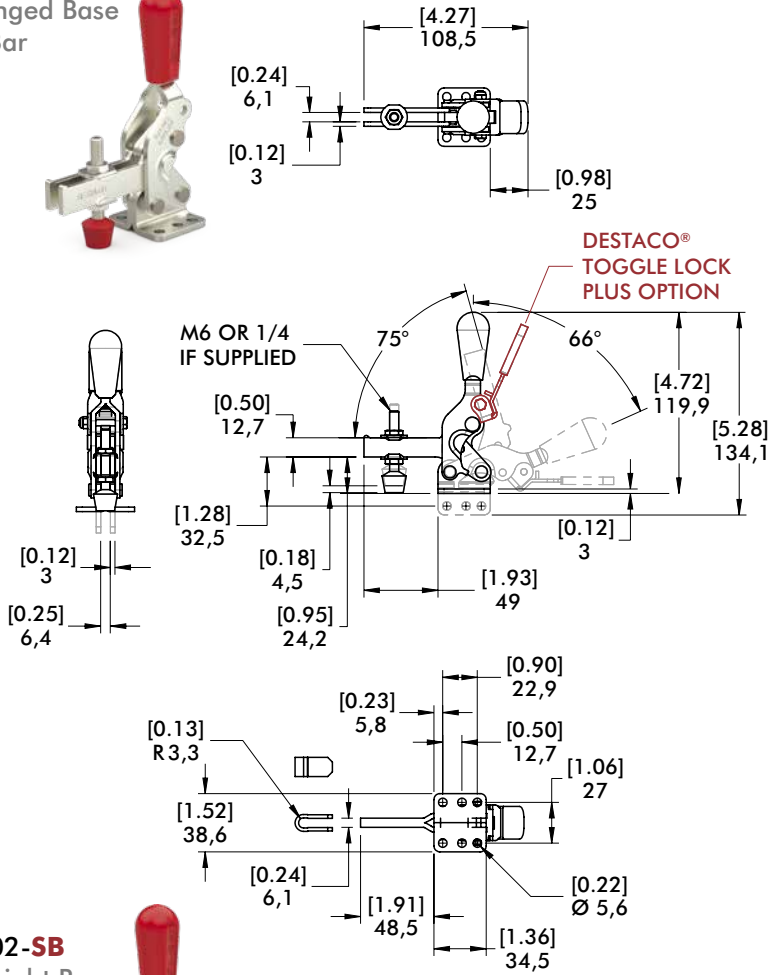

2002-SB Straight Base Solid Bar



mm [INCH]
THIRD ANGLE
PROJECTION

2002-U207/2002-UR207 with interchangeable Series 207 Mounting Pattern

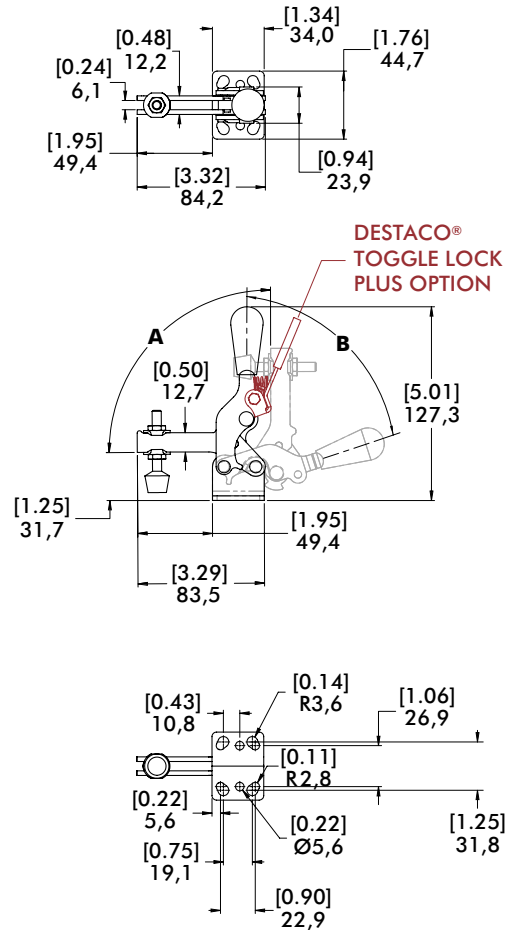

Model	A	B
2002-U207	90°	72°
2002-UR207	75°	57°

2002 SERIES

Vertical Hold Down Clamps | Dimensions | -UF

2002-UF
 Flanged Base
 U-Bar
 DESTACO®
 Toggle Lock
 Plus

